

M-05-13  
REV. D  
SEPTEMBER 2007

# TE-25 TE-25L

## MAINTENANCE MANUAL

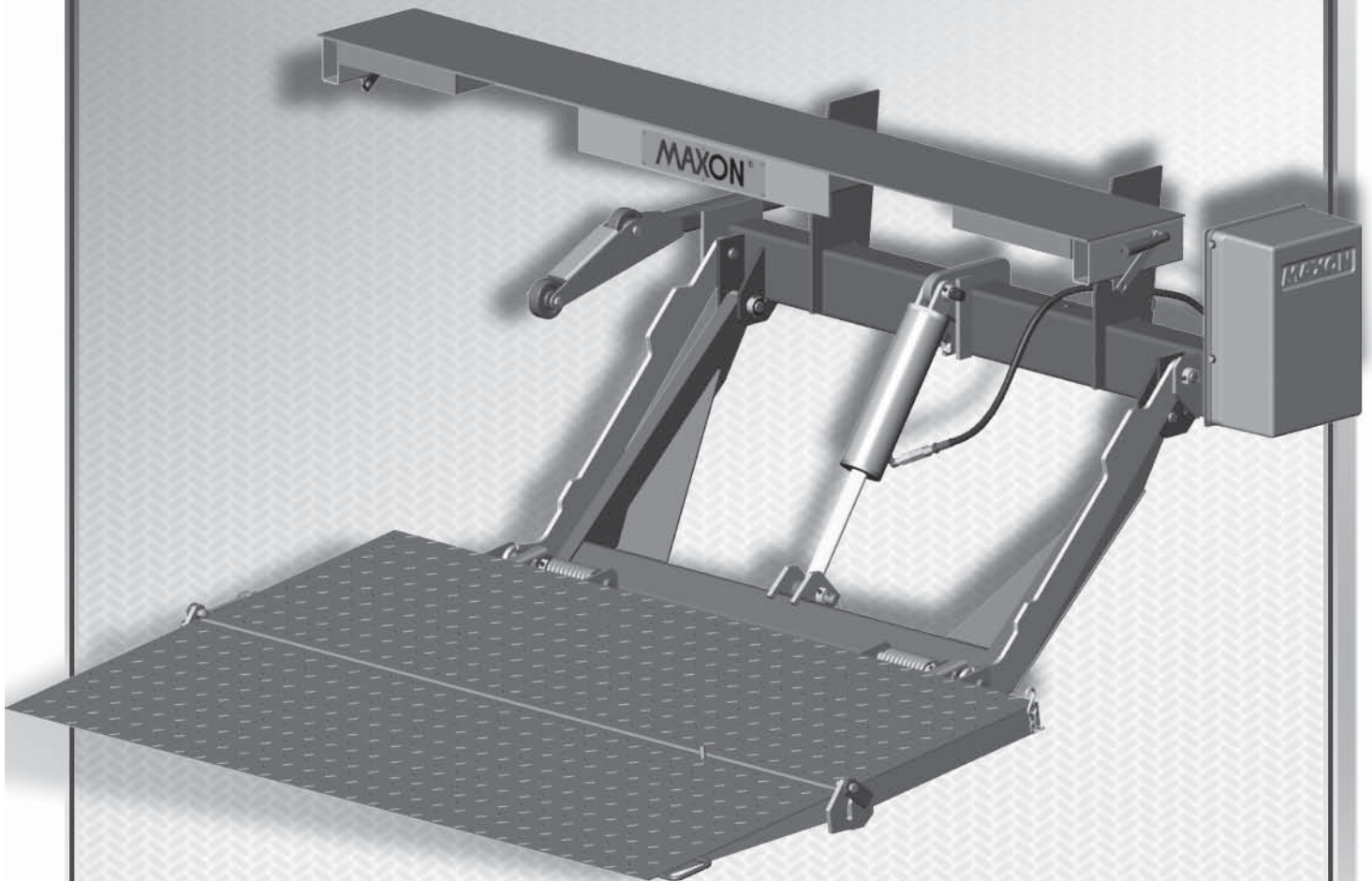

# MAXON®



# MAXON<sup>®</sup>

## LIFT CORP.

11921 Slauson Ave.  
Santa Fe Springs, CA. 90670

### CUSTOMER SERVICE:

TELEPHONE (562) 464-0099 TOLL FREE (800) 227-4116

FAX: (888) 771-7713

NOTE: For latest version of all Manuals (and replacements), download the Manuals from Maxon's website at [www.maxonlift.com](http://www.maxonlift.com).

## WARRANTY/ RMA POLICY & PROCEDURE

### LIFTGATE WARRANTY

Type of Warranty: Full Parts and Labor

Term of Warranty: Standard Liftgates - 2 years from ship date or 6,000 cycles  
Premium Liftgates - 2 years from ship date or 10,000 cycles

This warranty shall not apply unless the product is installed, operated and maintained in accordance with MAXON Lift's specifications as set forth in MAXON Lift's Installation, Operation and Maintenance manuals. This warranty does not cover normal wear, maintenance or adjustments, damage or malfunction caused by improper handling, installation, abuse, misuse, negligence, or carelessness of operation. In addition, this warranty does not cover equipment that has had unauthorized modifications or alterations made to the product.

MAXON agrees to replace any components which are found to be defective during the first 2 years of service, and will reimburse for labor based on MAXON's Liftgate Warranty Flat Rate Schedule. (Copy of the Flat Rate is available at [www.maxonlift.com](http://www.maxonlift.com).)

All warranty repairs must be performed by an authorized MAXON warranty facility. For any repairs that may exceed \$500, including parts and labor, MAXON's Technical Service Department must be notified and an "Authorization Number" obtained.

All claims for warranty must be received within 30 Days of the repair date, and include the following information:

1. Liftgate Model Number and Serial Number
2. The End User must be referenced on the claim
3. Detailed Description of Problem
4. Corrective Action Taken, and Date of Repair
5. Parts used for Repair, Including MAXON Part Number(s)
6. MAXON R.M.A. # and/or Authorization # if applicable (see below)
7. Person contacted at MAXON if applicable
8. Claim must show detailed information i.e. Labor rate and hours of work performed

Warranty claims can also be placed online at [www.maxonlift.com](http://www.maxonlift.com). Online claims will be given priority processing.

All claims for warranty will be denied if paperwork has not been received or claim submitted via Maxon website for processing by MAXON's Warranty Department within 30 days of repair date.

All components may be subject to return for inspection, prior to the claim being processed. MAXON products may not be returned without prior written approval from MAXON's Technical Service Department. Returns must be accompanied by a copy of the original invoice or reference with original invoice number and are subject to a credit deduction to cover handling charges and any necessary reconditioning costs. **Unauthorized returns will be refused and will become the responsibility of the returnee.**

Any goods being returned to MAXON Lift must be pre-approved for return, and have the R.M.A. number written on the outside of the package in plain view, and returned freight prepaid. All returns are subject to a 15% handling charge if not accompanied by a detailed packing list. Returned parts are subject to no credit and returned back to the customer. Defective parts requested for return must be returned within 30 days of the claim date for consideration to:

MAXON Lift Corp.  
10321 Greenleaf Ave., Santa Fe Springs, CA 90670  
Attn: RMA# \_\_\_\_\_

MAXON's warranty policy does not include the reimbursement for travel time, towing, vehicle rental, service calls, oil, batteries or loss of income due to downtime. Fabrication or use of non Maxon parts, which are available from MAXON, are also not covered.

MAXON's Flat Rate Labor Schedule takes into consideration the time required for diagnosis of a problem.

All Liftgates returned are subject to inspection and a 15% restocking fee. Any returned Liftgates or components that have been installed or not returned in new condition will be subject to an additional reworking charge, which will be based upon the labor and material cost required to return the Liftgate or component to new condition.

### PURCHASE PART WARRANTY

Term of Warranty: 1 Year from Date of Purchase.

Type of Warranty: Part replacement only. MAXON will guarantee all returned genuine MAXON replacement parts upon receipt and inspection of parts and original invoice.

All warranty replacements parts will be sent out via ground freight. If a rush shipment is requested, all freight charges will be billed to the requesting party.

# TABLE OF CONTENTS

<b>WARNING</b> .....	<b>6</b>
LIFTGATE TERMINOLOGY TE-25 .....	9
<b>PERIODIC MAINTENANCE</b> .....	<b>10</b>
PERIODIC MAINTENANCE CHECKS .....	10
PERIODIC MAINTENANCE CHECKLIST .....	11
CHECKING HYDRAULIC FLUID .....	12
CHANGING HYDRAULIC FLUID .....	14
PLATFORM ADJUSTMENT .....	16
REPLACING PLATFORM TORSION SPRING .....	18
SAFETY HOOK MAINTENANCE .....	20
<b>PARTS BREAKDOWN</b> .....	<b>21</b>
TE-25 MAIN ASSEMBLY .....	21
EXTENSION PLATE ASSEMBLY .....	23
LIFT FRAME & PARALLEL ARMS .....	24
PLATFORM & FLIPOVER ASSEMBLY (RAMP) .....	26
PUMP COVER & MOUNTING PLATE ASSEMBLY .....	27
GRAVITY DOWN HYDRAULIC COMPONENTS .....	28
12 VDC POWER UNIT (GRAVITY DOWN).....	30
24 VDC POWER UNIT (GRAVITY DOWN).....	32
POWER DOWN HYDRAULIC COMPONENTS .....	35
12 VDC POWER UNIT (POWER DOWN).....	36
DECALS .....	38
CONTROL SWITCH AND POWER CABLE .....	39
<b>HYDRAULIC SYSTEM DIAGRAMS</b> .....	<b>40</b>
HYDRAULIC SCHEMATIC (GRAVITY DOWN).....	40

HYDRAULIC SCHEMATIC (POWER DOWN) ..... 41

**ELECTRICAL SYSTEM DIAGRAMS ..... 42**

ELECTRICAL SCHEMATIC (GRAVITY DOWN) ..... 42

ELECTRICAL SCHEMATIC (POWER DOWN) ..... 43

**TROUBLESHOOTING ..... 44**

PLATFORM WILL NOT RAISE..... 44

PLATFORM RAISES BUT LEAKS DOWN ..... 45

PLATFORM RAISES PARTIALLY AND STOPS..... 46

LIFTGATE WILL NOT LIFT RATED CAPACITY ..... 47

PLATFORM RAISES SLOWLY ..... 48

PLATFORM WILL NOT LOWER, LOWERS TOO SLOWLY OR TOO QUICKLY ..... 49

Comply with the following **WARNINGS** while maintaining Liftgates. See Operation Manual for operating safety requirements.

## **⚠ WARNING**

- Read and understand the instructions in this **Maintenance Manual** before performing maintenance on the Liftgate.
- Before operating the Liftgate, read and understand the operating instructions in **Operation Manual**.
- Comply with all **WARNING** and instruction decals attached to the Liftgate.
- Keep decals clean and legible. If decals are illegible or missing, replace them. Free replacement decals are available from **Maxon Customer Service**.
- Consider the safety and location of bystanders and location of nearby objects when operating the Liftgate. Stand to one side of the platform while operating the Liftgate
- Do not allow untrained persons to operate the Liftgate.
- Do not stand, or allow obstructions, under the platform when lowering the Liftgate. **Be sure your feet are clear of the Liftgate.**
- **Keep fingers, hands, arms, legs, and feet clear of moving Liftgate parts (and platform edges) when operating the Liftgate.**
- **Correctly stow platform when not in use. Extended platforms could create a hazard for people and vehicles passing by.**
- **Disconnect Liftgate power cable from battery** before repairing or servicing Liftgate.
- Wear appropriate safety equipment such as protective eyeglasses, faceshield and clothing while performing maintenance on the Liftgate and handling the battery. Debris from drilling and contact with battery acid may injure unprotected eyes and skin.
- Be careful working by an automotive type battery. Make sure the work area is well ventilated and there are no flames or sparks near the battery. Never lay objects on the battery that can short the terminals together. If battery acid gets in your eyes, immediately seek first aid. If acid gets on your skin, immediately wash it off with soap and water.
- If an emergency situation arises (vehicle or Liftgate) while operating the Liftgate, release the control switch to stop the Liftgate.
- A correctly installed Liftgate operates smoothly and reasonably quiet. The only noticeable noise during operation comes from the power unit while the platform is raised. Listen for scraping, grating and binding noises and correct the problem before continuing to operate Liftgate.
- If it is necessary to stand on the platform while maintaining the Liftgate, keep your feet and any objects clear of the inboard edge of the platform. Your feet or objects on the platform could be trapped between the platform and the Liftgate extension plate.
- Never perform unauthorized modifications on the Liftgate. Modifications may result in early failure of the Liftgate and may create hazards for Liftgate operators and maintainers.

**MAXON**<sup>®</sup>

11921 Slauson Ave. Santa Fe Springs, CA. 90670 (800) 227-4116 FAX (888) 771-7713

- Use only **Maxon Authorized Parts** for replacement parts. Provide Liftgate model and serial number information with your parts order. Order replacement parts from:

**MAXON LIFT CORP. Customer Service**  
**11921 Slauson Ave., Santa Fe Springs, CA 90670**  
**Phone: (800) 227-4116**

- To order parts by e-mail, submit orders to **cservice@maxonlift.com**.
- Recommended practices for welding on steel parts are contained in the current **AWS (American Welding Society) D1.1 Structural Welding Code - Steel**. Damage to Liftgate and/or vehicle, and personal injury could result from welds that are done incorrectly.
- Recommended practices for welding on aluminum parts are contained in the current **AWS (American Welding Society) D2.1 Structural Welding Code - Aluminum**. Damage to Liftgate and/or vehicle, and personal injury could result from welds that are done incorrectly.

**MAXON**<sup>®</sup>

11921 Slauson Ave. Santa Fe Springs, CA. 90670 (800) 227-4116 FAX (888) 771-7713

THIS PAGE INTENTIONALLY LEFT BLANK



# LIFTGATE TERMINOLOGY

## TE-25

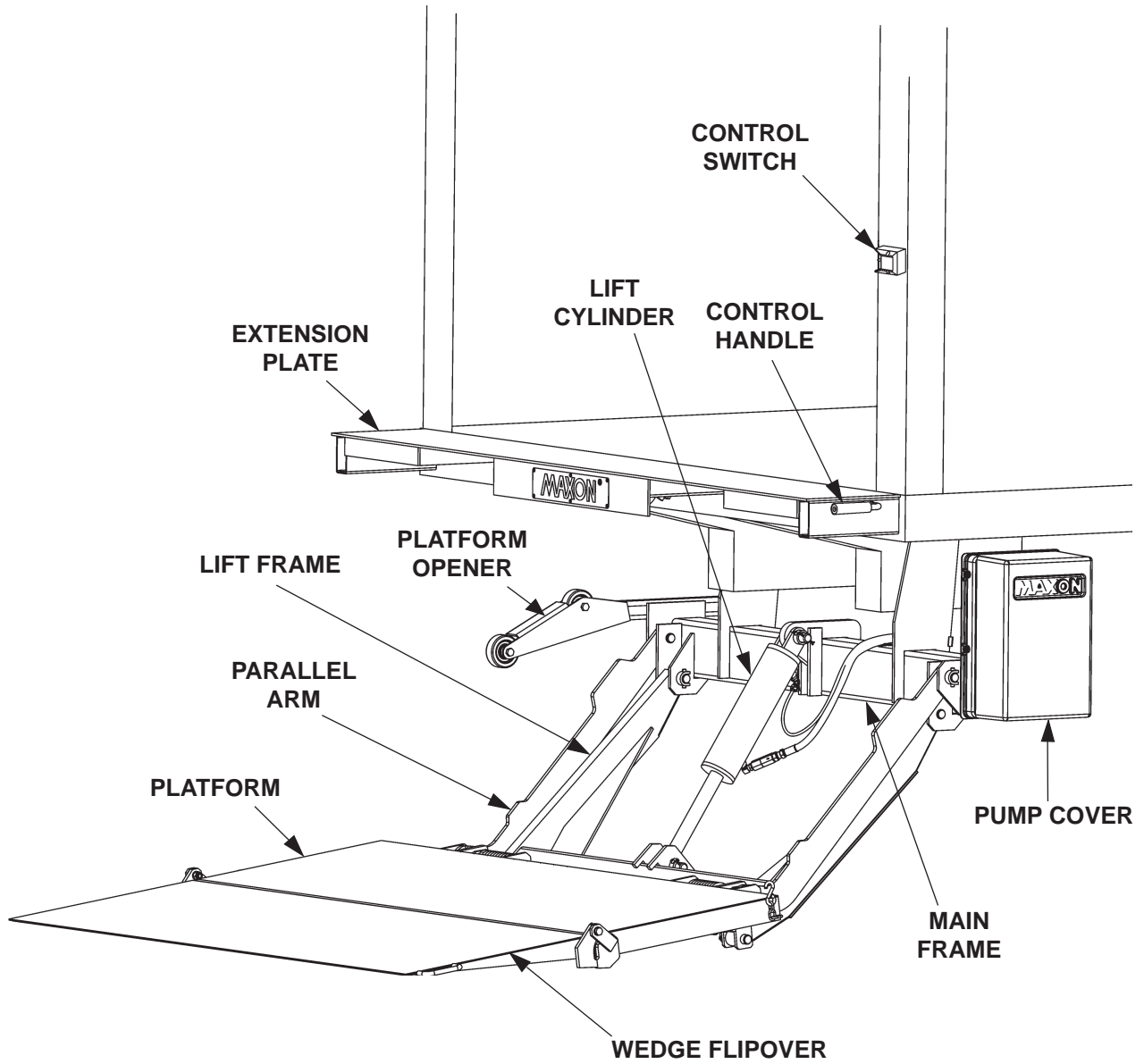

## PERIODIC MAINTENANCE

### PERIODIC MAINTENANCE CHECKS

#### **⚠ WARNING**

**Never operate the Liftgate with parts loose or missing.**

**NOTE:** Make sure vehicle is parked on level ground while performing the maintenance checks.

### **Quarterly or 1250 Cycles (whichever occurs first)**

Check the hydraulic fluid level in the pump reservoir. Refer to the **CHECKING HYDRAULIC FLUID** procedure in the **PERIODIC MAINTENANCE** section.

If hydraulic fluid appears contaminated, refer to the **CHANGING HYDRAULIC FLUID** procedure in the **PERIODIC MAINTENANCE** section.

Keep track of the grade of hydraulic fluid in the pump reservoir and never mix two different grades of fluid.

Check all hoses and fittings for chafing and fluid leaks. Tighten loose fittings or replace parts as required.

Check electrical wiring for chafing and make sure wiring connections are tight and free of corrosion. Use dielectric grease to protect electrical connections.

Check that all **WARNING and instruction decals** are in place. Also, make sure decals are legible and decals are clean and undamaged.

Check that all bolts, nuts, and roll pins are in place. Make sure roll pins protrude evenly from both sides of hinge pin collar. Replace fasteners and roll pins if necessary.

Check for rust and oily surfaces on Liftgate. If there is rust or oil on Liftgate or if the Liftgate is dirty, clean it off. Touch up the paint where bare metal is showing.

### **Semi-annually or 2500 Cycles (whichever occurs first)**

Visually check the platform hinge pins for excessive wear and broken welds. See **PARTS BREAKDOWN** section for replacement parts. Also, do the **Quarterly or 1250 Cycles** maintenance checks.

**MAXON**<sup>®</sup>

11921 Slauson Ave. Santa Fe Springs, CA. 90670 (800) 227-4116 FAX (888) 771-7713

## PERIODIC MAINTENANCE CHECKLIST

**NOTE:** Make sure vehicle is parked on level ground while performing the maintenance checks.

### Quarterly or 1250 Cycles (whichever occurs first)

- Check the level and condition of the hydraulic fluid.
- Visually check all hoses for chafing and fluid leaks. Tighten loose fittings or replace parts as required.
- Check electrical wiring for chafing and make sure wiring connections are tight and free of corrosion. Use dielectric grease to protect electrical connections.
- Check that all **WARNING and instruction decals** are in place. Also, make sure decals are legible and decals are clean and undamaged.
- Check that all bolts, nuts, and roll pins are in place. Make sure roll pins protrude evenly from both sides of hinge pin collar. Replace fasteners and roll pins if necessary.

### CAUTION

**Damaged cylinder seals and contaminated hydraulic fluid can result from painting the polished portion of the cylinder rod. To prevent damage, protect the exposed polished portion of the cylinder rod while painting.**

- Check for rust and oily surfaces on Liftgate. If there is rust or oil on Liftgate or if the Liftgate is dirty, clean it off. Touch up the paint where bare metal is showing.

### Semi-annually or 2500 Cycles (whichever occurs first)

- Visually check the platform hinge pins for excessive wear and broken welds.
- Do the **Quarterly or 1250 Cycles Checks** on this checklist.

# PERIODIC MAINTENANCE

## CHECKING HYDRAULIC FLUID

### CAUTION

Keep dirt, water and other contaminants from entering the hydraulic system. Before opening the hydraulic fluid reservoir filler cap, drain plug and hydraulic lines, clean up contaminants that can get in the openings. Also, protect the openings from accidental contamination.

**NOTE:** Use correct grade of hydraulic fluid for your location.

**+50 to +120 Degrees F - Grade ISO 32**

**Below + 70 Degrees F - Grade ISO 15 or MIL-H-5606**

See **TABLES 13-2 and 13-3** for recommended brands.

1. Unbolt & remove pump cover (FIG. 12-1).

**NOTE:** If the hydraulic fluid in the reservoir is contaminated, do the **CHANGING HYDRAULIC FLUID** procedure in this section.

**NOTE:** If you have a power down power unit, skip instructions 2 & 3.

2. For gravity down power unit, check the hydraulic fluid level "H" in reservoir (FIG. 12-2 and TABLE 12-1). If needed, add fluid to the reservoir as follows.

PLATFORM POSITION	FLUID LEVEL "H"
STOWED	1-7/8" to 2-3/8"
VEHICLE BED HEIGHT	1-7/8" to 2-3/8"
ON THE GROUND	3-1/2" to 4"

**GRAVITY DOWN FLUID LEVEL**  
**TABLE 12-1**

3. Pull out (no threads) filler cap (FIG. 12-2). Fill the reservoir with hydraulic fluid to level "H" shown in FIG. 12-2 and TABLE 12-1. Reinstall filler cap (FIG. 12-2).

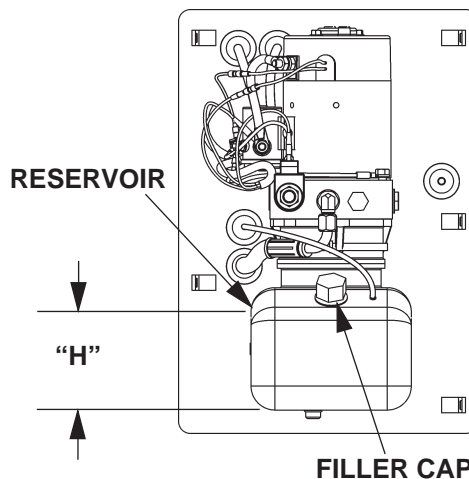
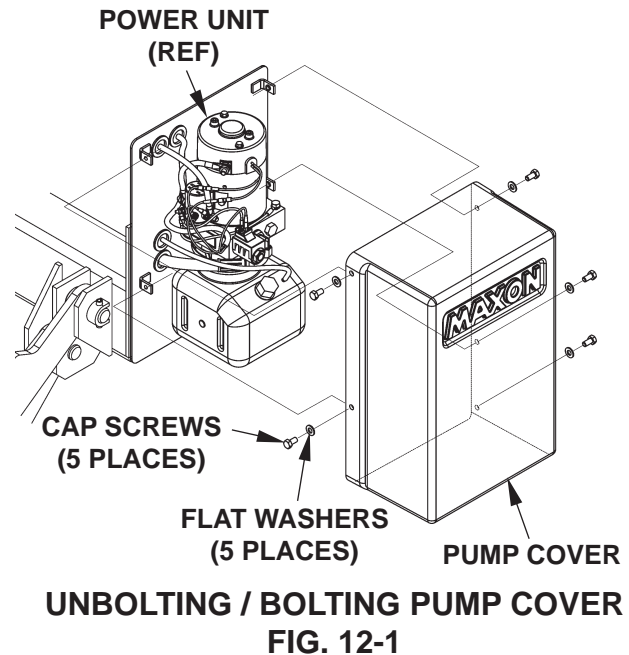

4. For power down power unit, check the hydraulic fluid level “H” in reservoir (**FIG. 13-1** and **TABLE 13-1**). If needed, add fluid to the reservoir as follows.

PLATFORM POSITION	FLUID LEVEL “H”
STOWED	2-5/8” to 3-1/8”
VEHICLE BED HEIGHT	2-5/8” to 3-1/8”
ON THE GROUND	2-3/8” to 2-7/8”

**POWER DOWN FLUID LEVEL  
TABLE 13-1**

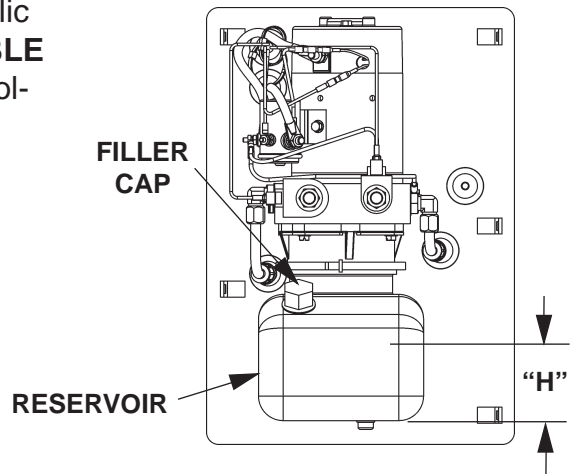

**POWER DOWN POWER UNIT  
FIG. 13-1**

5. Pull out (no threads) filler cap (**FIG. 13-1**). Fill the reservoir with hydraulic fluid to level “H” shown in **FIG. 13-1** and **TABLE 13-1**. Reinstall filler cap (**FIG. 13-1**).

6. Bolt on the pump cover (**FIG. 12-1**). Torque the bolts (cap screws) to **10 - 14 lbs.- in.**

ISO 32 HYDRAULIC OIL	
RECOMMENDED BRANDS	PART NUMBER
AMSOIL	AWH-05
CHEVRON	HIPERSYN 32
KENDALL	GOLDEN MV
SHELL	TELLUS T-32
EXXON	UNIVIS N-32
MOBIL	DTE-13M, DTE-24, HYDRAULIC OIL-13

**TABLE 13-2**

ISO 15 OR MIL-H-5606 HYDRAULIC OIL	
RECOMMENDED BRANDS	PART NUMBER
AMSOIL	AWF-05
CHEVRON	FLUID A, AW-MV-15
KENDALL	GLACIAL BLU
SHELL	TELLUS T-15
EXXON	UNIVIS HVI-13
MOBIL	DTE-11M
ROSEMEAD	THS FLUID 17111

**TABLE 13-3**

# PERIODIC MAINTENANCE CHANGING HYDRAULIC FLUID

## CAUTION

Keep dirt, water and other contaminants from entering the hydraulic system. Before opening the hydraulic fluid reservoir filler cap, drain plug and hydraulic lines, clean up contaminants that can get in the openings. Also, protect the openings from accidental contamination.

**NOTE:** Use correct grade of hydraulic fluid for your location.

**+50 to +120 Degrees F - Grade ISO 32**

**Below + 70 Degrees F - Grade ISO 15 or MIL-H-5606**

See **TABLES 13-2 and 13-3** for recommended brands.

### GRAVITY DOWN LIFTGATES

1. Remove the pump cover (**FIG. 15-1**). Place empty 5 gallon bucket under drain plug (**FIG. 14-1**).
2. Lower platform to ground. Pull out (no threads) drain plug (**FIG. 14-1**). Drain hydraulic fluid from system. Reinstall drain plug.
3. Pull out (no threads) filler cap (**FIG. 14-1**) and refill reservoir with hydraulic fluid to level shown in **FIG. 14-1**. Reinstall filler cap (**FIG. 14-1**).
4. Bolt on the pump cover as shown in **FIG. 15-1**. Torque the bolts (cap screws) to **10 - 14 lbs.- in.**

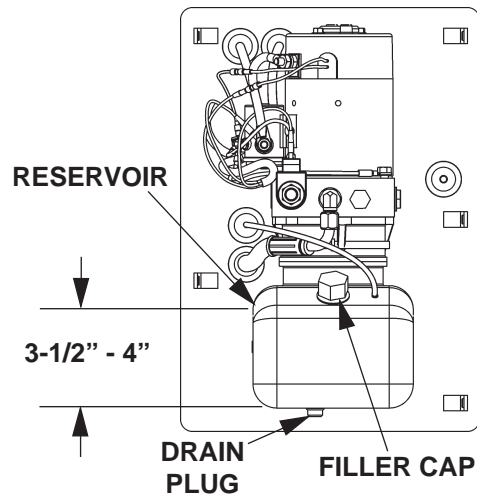

**LIFTGATE SHOWN WITH GRAVITY  
DOWN PUMP & MOTOR  
FIG. 14-1**

### POWER DOWN LIFTGATES

1. Remove the pump cover (**FIG. 15-1**). Place empty 5 gallon bucket under drain plug (**FIG. 14-1**).
2. Open and raise platform to vehicle bed height. Pull out (no threads) drain plug (**FIG. 14-1**). Drain hydraulic fluid.
3. Disconnect the motor power cable (**FIG. 14-2**) from starter solenoid. Lower the platform while draining the remaining hydraulic fluid from system. Reinstall drain plug. Reconnect the motor power cable to starter solenoid.
4. Pull out (no threads) filler cap (**FIG. 14-1**) and refill reservoir with hydraulic fluid to level shown in **FIG. 14-1**. Reinstall filler cap (**FIG. 14-1**).

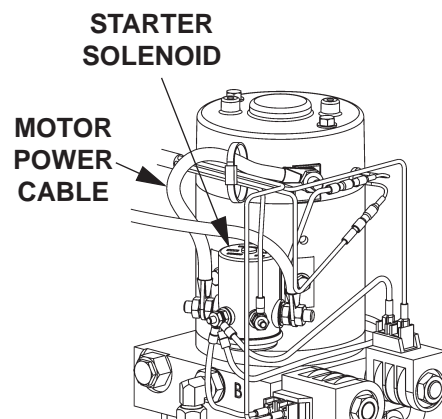

**POWER DOWN PUMP  
FIG. 14-2**

5. Bolt on the pump cover as shown in **FIG. 15-1**. Torque the bolt (cap screws) to **10 - 14 lbs.- in.**

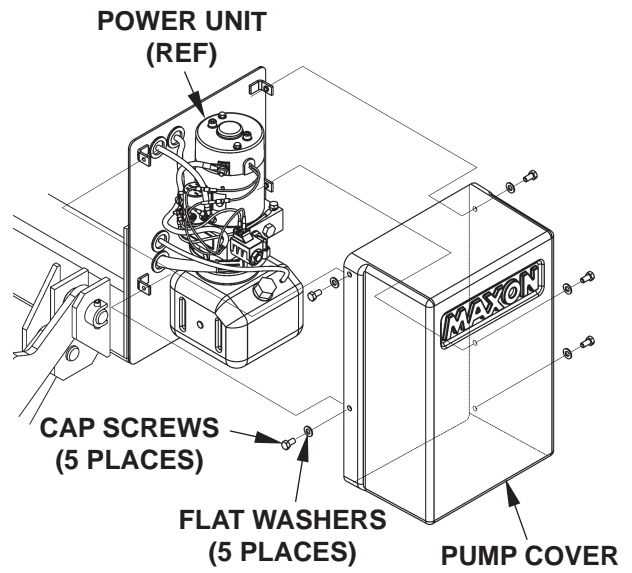

**UNBOLTING / BOLTING PUMP COVER**  
**FIG. 15-1**

# PERIODIC MAINTENANCE PLATFORM ADJUSTMENT

**NOTE:** Before doing the following procedure, make sure vehicle is parked on level ground.

1. Make sure platform is at ground level. Unfold the platform and flipover. As the platform first touches the ground, shackles and tip of flipover must touch the ground at the same time (**FIG. 16-1**). If the shackles and the tip of flipover touch the ground at the same time, **RAISE** platform to bed height. Tip of flipover should be above bed level (**FIG. 16-2**). If indications are correct in both cases (**FIGS. 16-1 & 16-2**), Liftgate is installed correctly and no adjustment is needed. If indications are incorrect, continue with instruction 2.

**NOTE:** If tip of flipover touches first (**FIG. 16-3**), do instruction 2. If the shackle touches first (**FIG. 11-1**), skip instruction 2 and do 3.

2. Make sure platform is still at ground level. If the shackle is not touching the ground, measure and compare distance "A" (**FIG. 16-3**) with **TABLE 16-1** to determine the correct shim. Make shims as needed (**FIG. 16-5**). Weld shim as shown in **FIG. 16-4**.

RAISE TIP OF FLIPOVER THIS DISTANCE "B"	GRIND METAL FROM PLATFORM STOP
7/8"	1/16"
2"	1/8"
3"	3/16"
3-15/16"	1/4"

**TABLE 16-1**

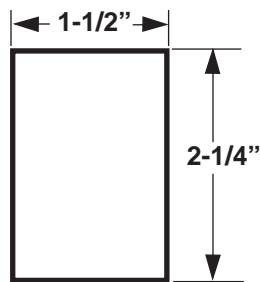

**SHIM (1/16", 1/8", 3/16", or 1/4")  
MADE FROM STEEL FLAT  
FIG. 16-5**

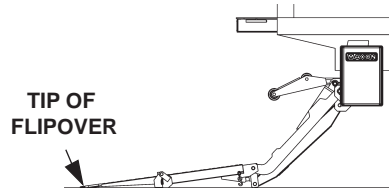

**PLATFORM & SHACKLES  
TOUCH GROUND  
FIG. 16-1**

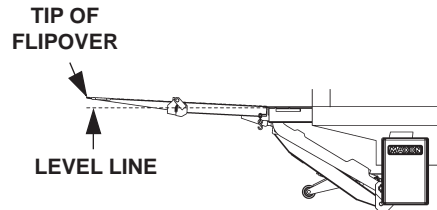

**PLATFORM EDGE ABOVE  
BED LEVEL  
FIG. 16-2**

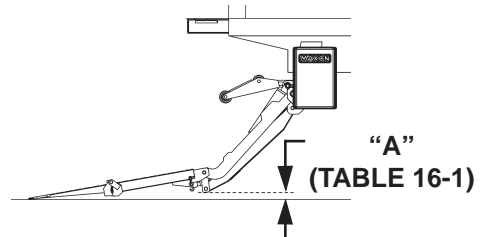

**SHACKLES DO NOT TOUCH  
GROUND  
FIG. 16-3**

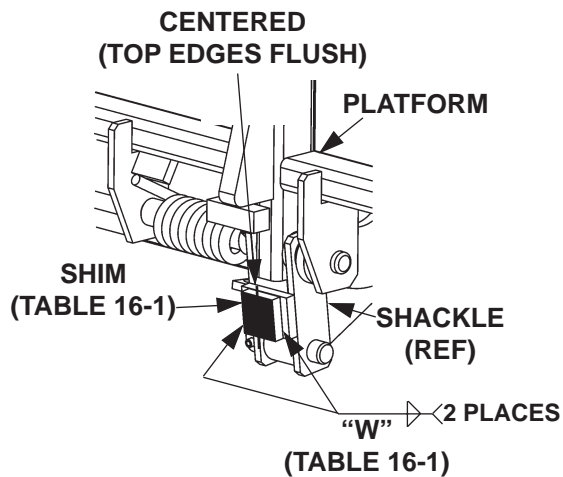

**WELDING SHIMS (CURBSIDE SHOWN)  
FIG. 16-4**



3. Make sure platform is still at ground level. If the tip of flipover is not touching the ground, measure and compare distance “B” (FIG. 17-1) with TABLE 17-1 to determine how much to grind from the platform stops (FIG. 17-2). Grind correct amount of metal (TABLE 17-1) from platform stop as shown in FIG. 17-2.

RAISE TIP OF FLIPOVER THIS DISTANCE “B”	GRIND METAL FROM PLATFORM STOP
7/8”	1/16”
2”	1/8”
3”	3/16”
3-15/16”	1/4”

TABLE 17-1

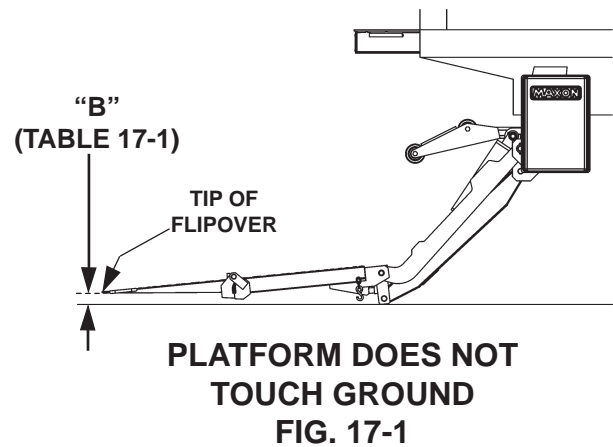

4. RAISE the platform, then LOWER it to the ground. As the platform first touches the ground, the tip of flipover and shackle should touch at the same time as shown in FIG. 16-1.

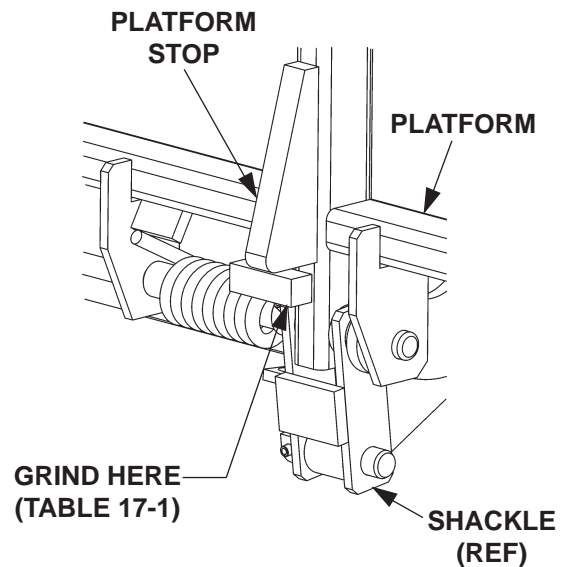

GRINDING PLATFORM STOPS (CURBSIDE SHOWN) FIG. 17-2

# PERIODIC MAINTENANCE

## REPLACING PLATFORM TORSION SPRING

**NOTE:** The following procedure shows how to replace torsion spring on RH side of platform. Use this procedure for replacing torsion spring on the LH side.

1. Fold flipover onto platform.
2. Fold platform.
3. Raise Liftgate to a convenient work height to gain access and release tension on the torsion spring.

**⚠ CAUTION**

**To prevent injury and equipment damage, make sure there is no tension on torsion spring before removing hinge pin.**

4. Drive out the roll pin from pin collar on the platform hinge bracket. Drive the platform hinge pin outboard from the shackle just enough to free the torsion spring and bushing (**FIG. 18-1**). Remove torsion spring and bushing.
5. Install the torsion spring and bushing as shown in (**FIG. 18-2**). Make sure the long leg of the spring is inserted in the bracket located on the shackle. Make sure the short end of the spring is visible and resting against the block on the platform hinge bracket (**FIG. 18-2**).

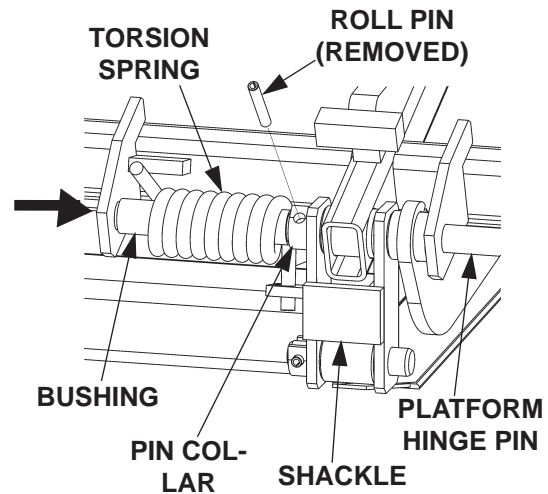

**REMOVING HINGE PIN  
(RH SIDE OF PLATFORM SHOWN)  
FIG. 18-1**

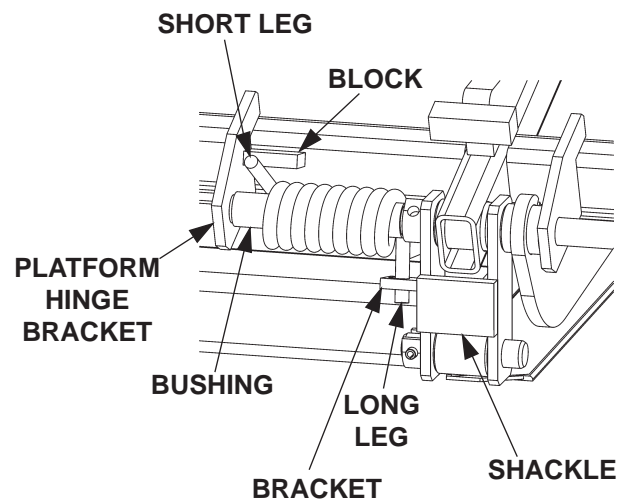

**INSTALLING HINGE PIN  
(RH SIDE OF PLATFORM SHOWN)  
FIG. 18-2**

6. Drive platform hinge pin inboard to correct position through the platform hinge bracket (**FIG. 19-1**). Line up the hole in the platform hinge pin with the hole in the pin collar. Install the roll pin through the pin collar until roll pin protrudes equally from both sides of the collar (**FIG. 19-1**).

7. Operate the Liftgate according to instructions in **Operation Manual** to make sure it operates correctly.

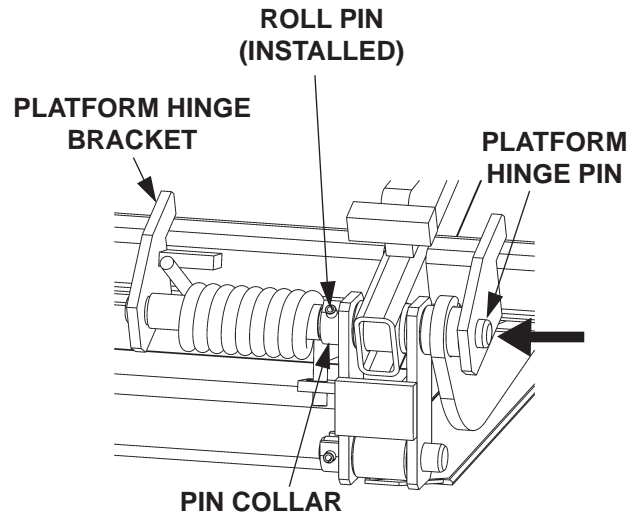

**FIG. 19-1**

# PERIODIC MAINTENANCE

## SAFETY HOOK MAINTENANCE

### CHECK SAFETY HOOK FUNCTION

1. When raising platform to stowed position, listen for sound of **safety hook** engaging **platform loop**.
2. When the Liftgate is stowed, see if **platform loop** is positioned above the **safety hook** as shown in **FIG. 20-1**.

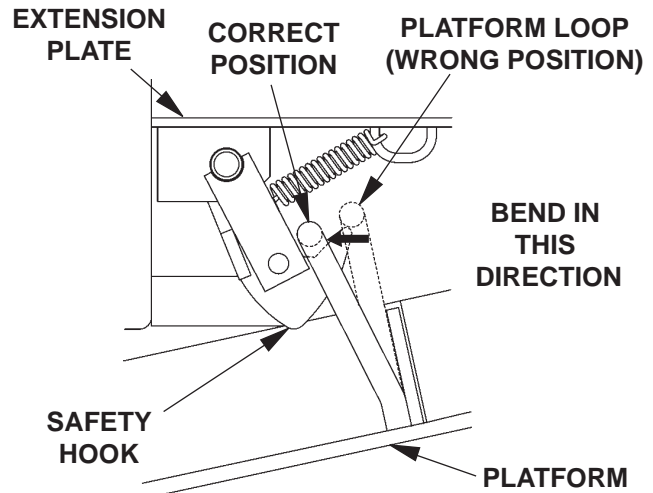

FIG. 20-1

### LOOP ADJUSTMENT

1. If the safety hook is not positioned correctly, **LOWER** platform to ground level (**Operation Manual**).
2. Adjust by bending the platform loop as shown in **FIG. 20-1**.
3. Stow the platform and check for correct safety hook position. Repeat adjustment if required.

### LUBRICATION (IF REQUIRED)

1. Make sure front surface of safety hook **FIG. 20-2** is lubricated with automotive grease. Apply grease if required.
2. Make sure control handle rod (**FIG. 20-2**) is lubricated where it has contact with brackets. Apply automotive grease if required.

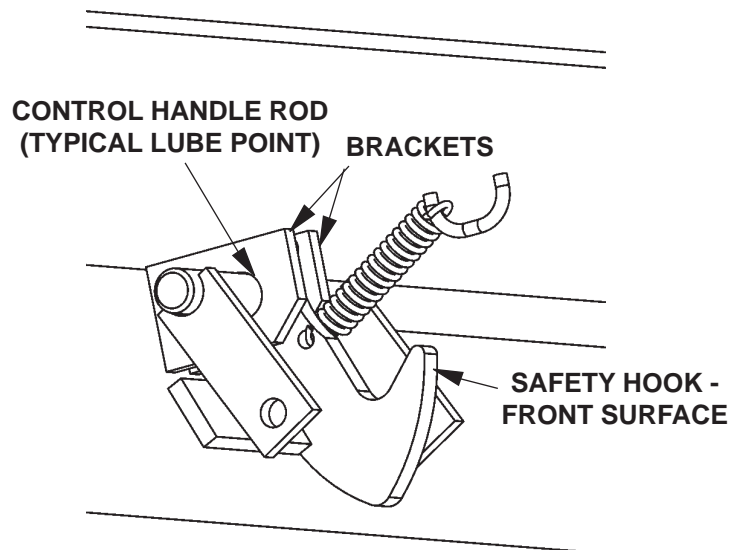

FIG. 20-2

**MAXON**

11921 Slauson Ave. Santa Fe Springs, CA. 90670 (800) 227-4116 FAX (888) 771-7713

# PARTS BREAKDOWN

## TE-25 MAIN ASSEMBLY

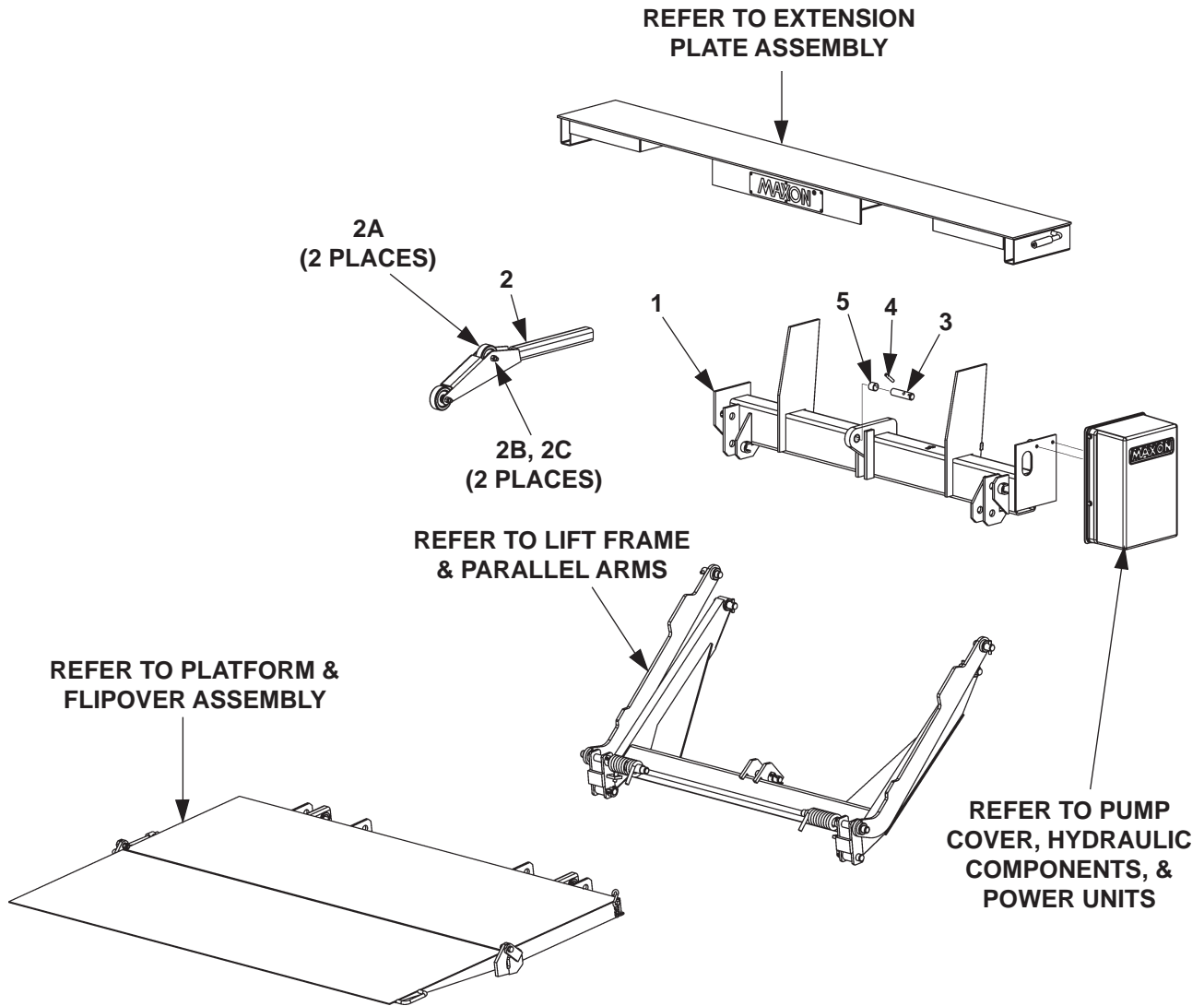

ITEM	QTY.	PART NO.	DESCRIPTION
1	1	266424-01	MAIN FRAME, TE-25
		267434-01	MAIN FRAME, TE-25L
2	1	280790-01	PLATFORM OPENER
2A	2	280082-01	ROLLER, OPENER, 3-1/2" DIA.
2B	2	900033-10	CAP SCREW, 1/2"-20 X 3-1/2" LG, GRADE 8
2C	2	901008	LOCK NUT, 1/2"-20
3	1	263018	CYLINDER PIN, 1" DIA X 4-1/8" LG.
4	1	221416	ROLL PIN, 3/8" X 2" LG.
5	1	260916-06	SELF LUBE BEARING, 1" DIA X 1" LG.

**MAXON®**

11921 Slauson Ave. Santa Fe Springs, CA. 90670 (800) 227-4116 FAX (888) 771-7713

**THIS PAGE INTENTIONALLY LEFT BLANK**

## EXTENSION PLATE ASSEMBLY

VIEWED FROM UNDER  
EXTENSION PLATE

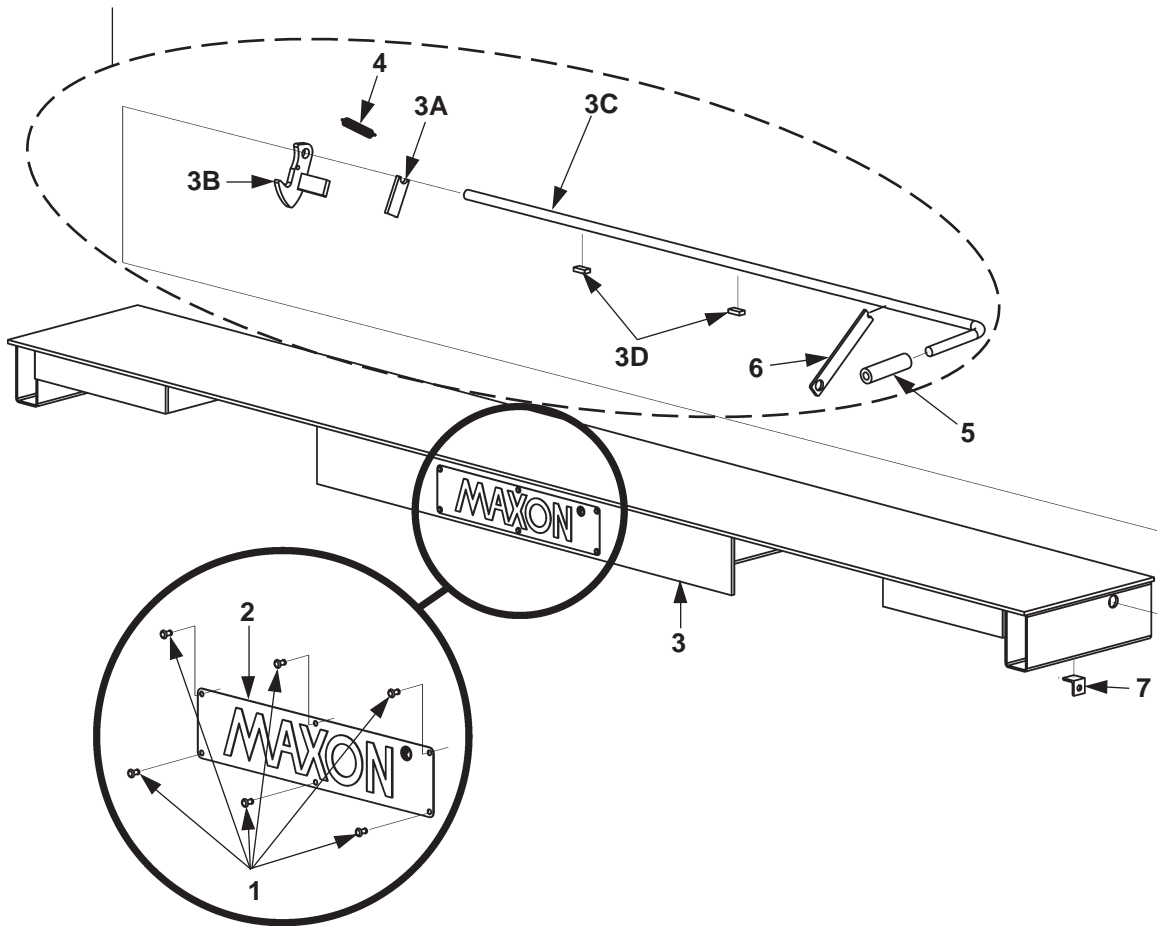

ITEM	QTY.	PART NO.	DESCRIPTION
1	6	207644	RIVET, 3/16" DIA, .40" LG
2	1	050175	MAXON PLATE
3	1	267418-01	EXTENSION PLATE WELDMENT
3A	1	262373	BRACKET
3B	1	263052	SAFETY HOOK WELDMENT
3C	1	262370-01	HANDLE (CURBSIDE)
3D	2	201561	FLAT, 1/4" X 1/2" X 1/2" LG
4	1	215345	EXTENSION SPRING, 7/64" X 2-1/2" LG
5	1	055011	HANDLE, RUBBER
6	1	203417	RENTAL LOCK BRACKET (OPTIONAL)
7	1	203570	INNER BRACKET, RENTAL LOCK (OPTIONAL)

# LIFT FRAME & PARALLEL ARMS

**MAXON**<sup>®</sup>

11921 Slauson Ave. Santa Fe Springs, CA. 90670 (800) 227-4116 FAX (888) 771-7713

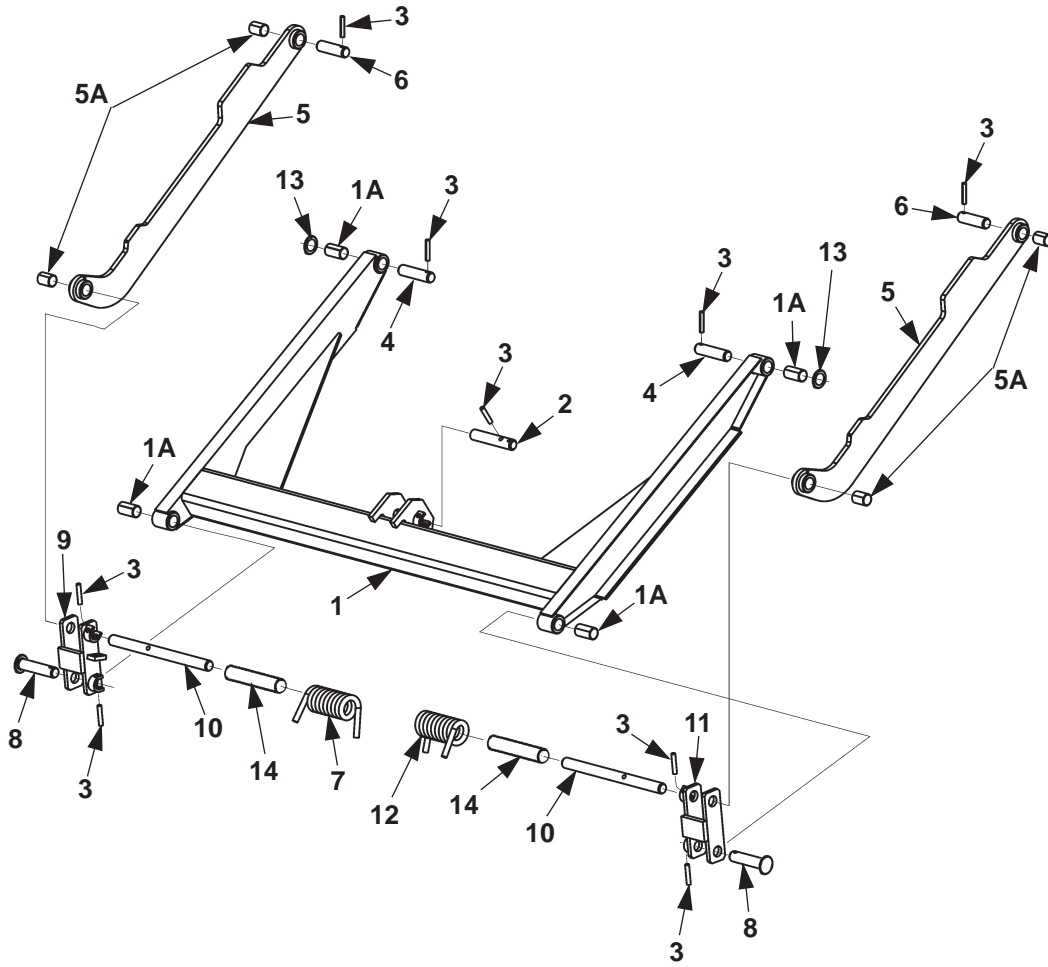



ITEM	QTY.	PART NO.	DESCRIPTION
1	1	263831	LIFT FRAME (TE-25)
		262383	LIFT FRAME, WIDE ARM (TE-25L)
1A	4	260916-03	SELF LUBE BEARING, 1" DIA X 1" LG.
2	1	263017	CYLINDER PIN
3	9	221416	ROLL PIN, 3/8" X 2" LG.
4	2	262342-02	PIN, 1" DIA X 4" LG.
5	2	263058	PARALLEL ARM
5A	4	260916-02	SELF LUBE BEARING, 1" DIA X 1-1/2" LG.
6	2	262342-03	PIN, 1" DIA X 3-1/2" LG.
7	1	281641-02	TORSION SPRING, LH (TE-25)
		280795-01	TORSION SPRING, LH (TE-25L)
8	2	281483-01	PIN WELDMENT, 1" DIA X 4" LG.
9	1	267414-02	SHACKLE, LH (TE-25)
		267435-01	SHACKLE, LH (TE-25L)
10	2	267416-01	PIN, 1" DIA X 13-1/4" LG.
11	1	267414-01	SHACKLE, RH (TE-25)
		267435-02	SHACKLE, RH (TE-25L)
12	1	281641-01	TORSION SPRING, RH (TE-25)
		280794-01	TORSION SPRING, RH (TE-25L)
13	2	908078-01	THRUST BEARING, 1" I.D.
14	2	091802-10	TUBE (BUSHING)

## PLATFORM & FLIPOVER ASSEMBLY (RAMP)

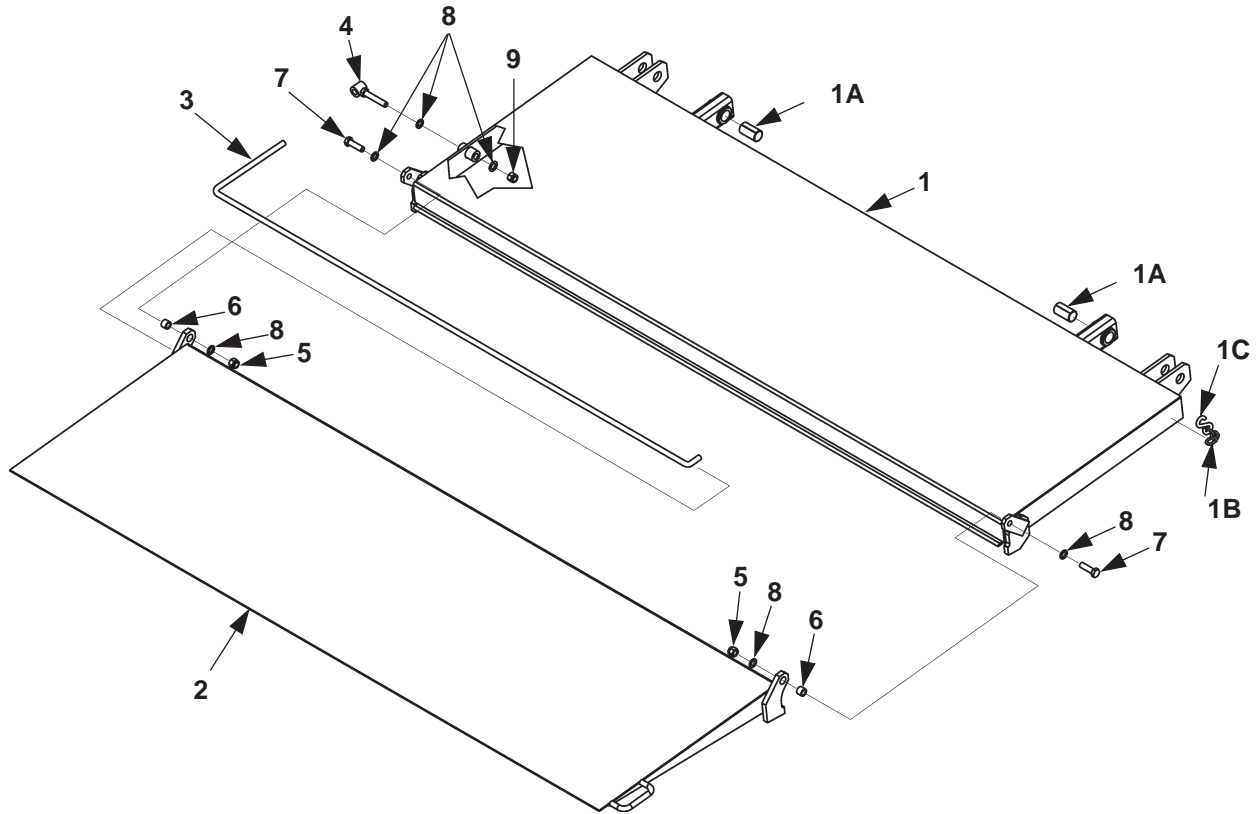

ITEM	QTY.	PART NO.	DESCRIPTION
1	1	267415-01	PLATFORM WELDMENT, 78-1/2" X 24"
1A	2	260916-03	SELF LUBE BEARING, 1" DIA X 2" LG.
1B	1	050162-16	CHAIN, # 2/0 X 3"LG
1C	1	260458	"S" HOOK, 1-3/4"
2	1	280819-01	FLIPOVER WELDMENT, 78-1/2" X 24"
3	1	280751-01	TORSION BAR
4	1	280749-02	ANCHOR BOLT (TE-25)
		280749-01	ANCHOR BOLT (TE-25L)
5	2	901008	LOCK NUT, 1/2"-20
6	2	280758-01	BUSHING, FLIPOVER
7	2	900033-4	CAP SCREW, 1/2"-20 X 1-3/4" LG, GRADE 8
8	6	902000-14	FLAT WASHER, 1/2"
9	1	901010	LOCK NUT, 1/2"-13

**MAXON®**

11921 Slauson Ave. Santa Fe Springs, CA. 90670 (800) 227-4116 FAX (888) 771-7713

## PUMP COVER & MOUNTING PLATE ASSEMBLY

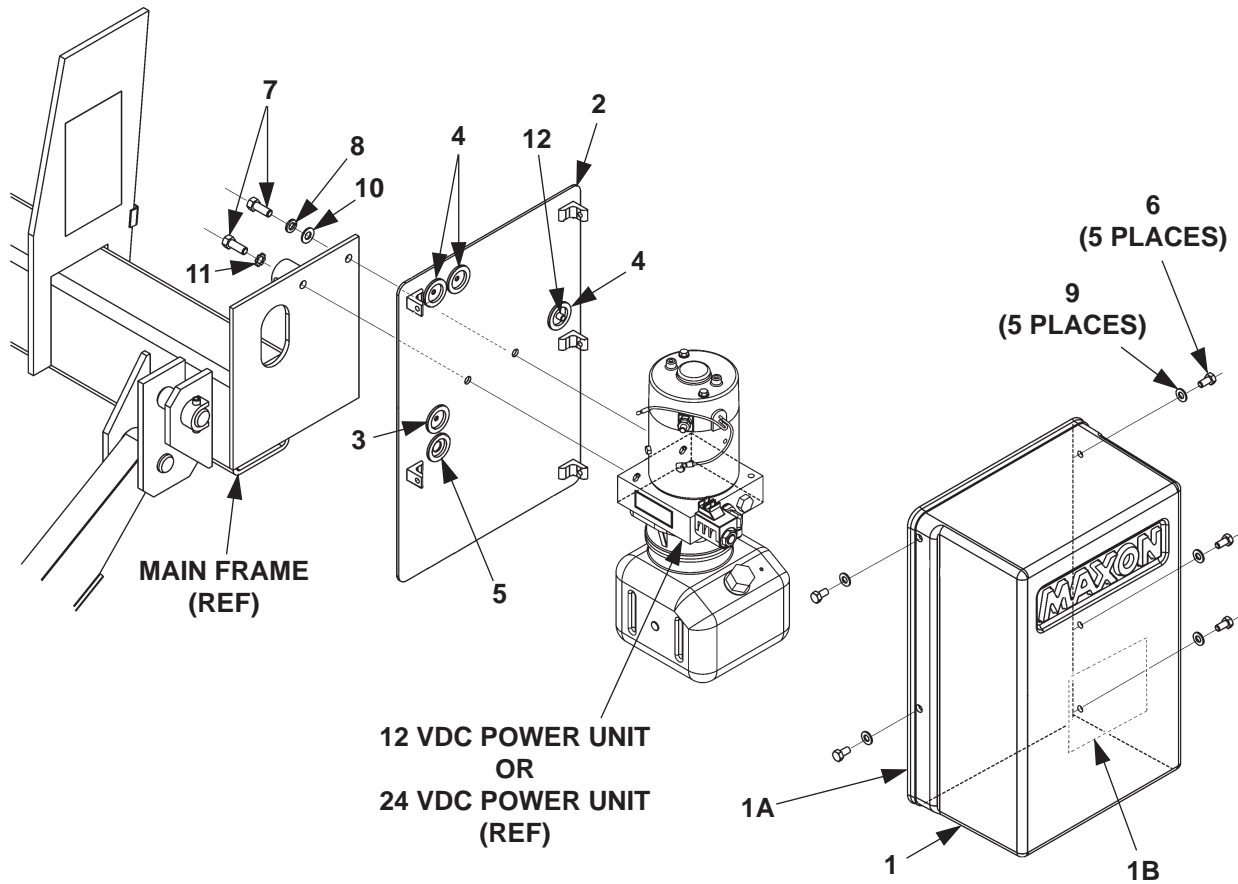

ITEM	QTY.	PART NO.	DESCRIPTION
1	1	266419-01	COVER ASSY
1A	1	093201-01	GASKET, RUBBER CHANNEL, 57-1/2" LG.
1B	1	261740	LABEL, OIL LEVEL
2	1	266427-01	PLATE, PUMP MOUNT
3	1	266428-01	GROMMET, 3/16" HOLE
4	3	266428-02	GROMMET, 1/4" HOLE
5	1	266428-06	GROMMET, 9/16" HOLE
6	5	900009-3	SCREW, CAP 5/16"-18 X 3/4" LG, GRADE 8
7	2	900014-4	SCREW, CAP 3/8"-16 X 1" LG, GRADE 8
8	1	902011-4	LOCK WASHER, 3/8"
9	5	902002-1	FLAT WASHER, 5/16"
10	1	902013-11	FLAT WASHER, 3/8"
11	1	903400-02	LOCK WASHER, EXTERNAL TOOTH, 3/8"
12	1	908022-02	PLUG, FLEXIBLE

## GRAVITY DOWN HYDRAULIC COMPONENTS

**MAXON®**

11921 Slauson Ave. Santa Fe Springs, CA. 90670 (800) 227-4116 FAX (888) 771-7713

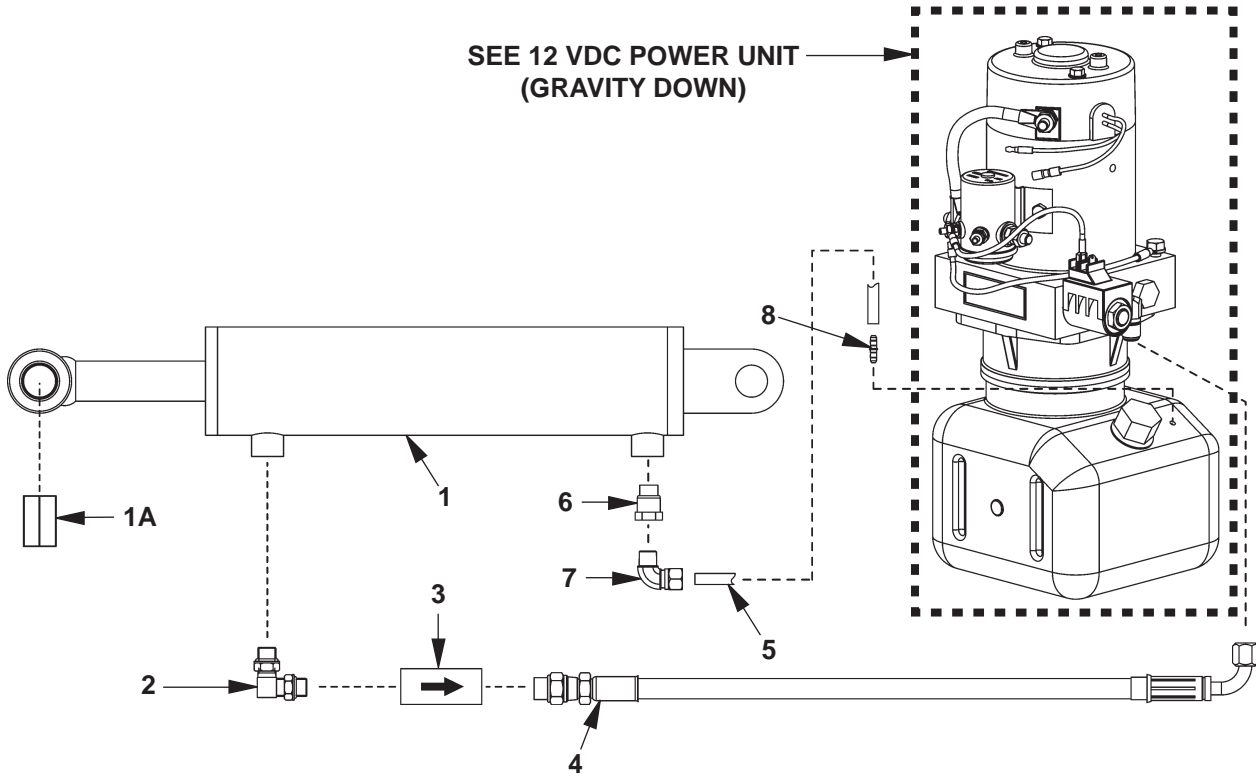

ITEM	QTY.	PART NO.	DESCRIPTION
1	1	266408-01	CYLINDER ASSY, 3-1/2" DIA X 10" STROKE X 1-1/2" ROD DIA (TE-25)
		266401-02	CYLINDER ASSY, 3-1/2" DIA X 10" STROKE X 1-1/4" ROD DIA (TE-25L)
1A	1	260916-03	BEARING, SELF LUBE
2	1	906722-01	ELBOW, 90 DEG O-RING, #6 M-M
3	1	906709-02	FLOW REGULATOR VALVE, 2 GPM
4	1	280635-01	HOSE ASSY, 3/8" HP, 54" LG.
5	1	224370-07	HOSE, PLASTIC 60-1/2" LG.
6	1	228012	ADAPTER, STRAIGHT THREAD, 9/16"-18 M - 1/4" F
7	1	202406	ELBOW, BRASS 1/4" x 1/4"
8	1	906728-01	DUAL BARBED FITTING, 1/64" I.D.

THIS PAGE INTENTIONALLY LEFT BLANK

## 12 VDC POWER UNIT (GRAVITY DOWN)

### CAUTION

To prevent damage to metal case starter solenoid, hold bottom terminal nut securely when loosening and tightening top terminal nut. Do not over-tighten the terminal nuts. For the 5/16" load terminals, torque nuts 35-40 lbs.-in. Torque the nuts on #10-32 control terminals 15-20 lbs.-in.

### CAUTION

To prevent damage when installing 2-way valves, torque valve cartridge nut to 30 lbs.-in. max.

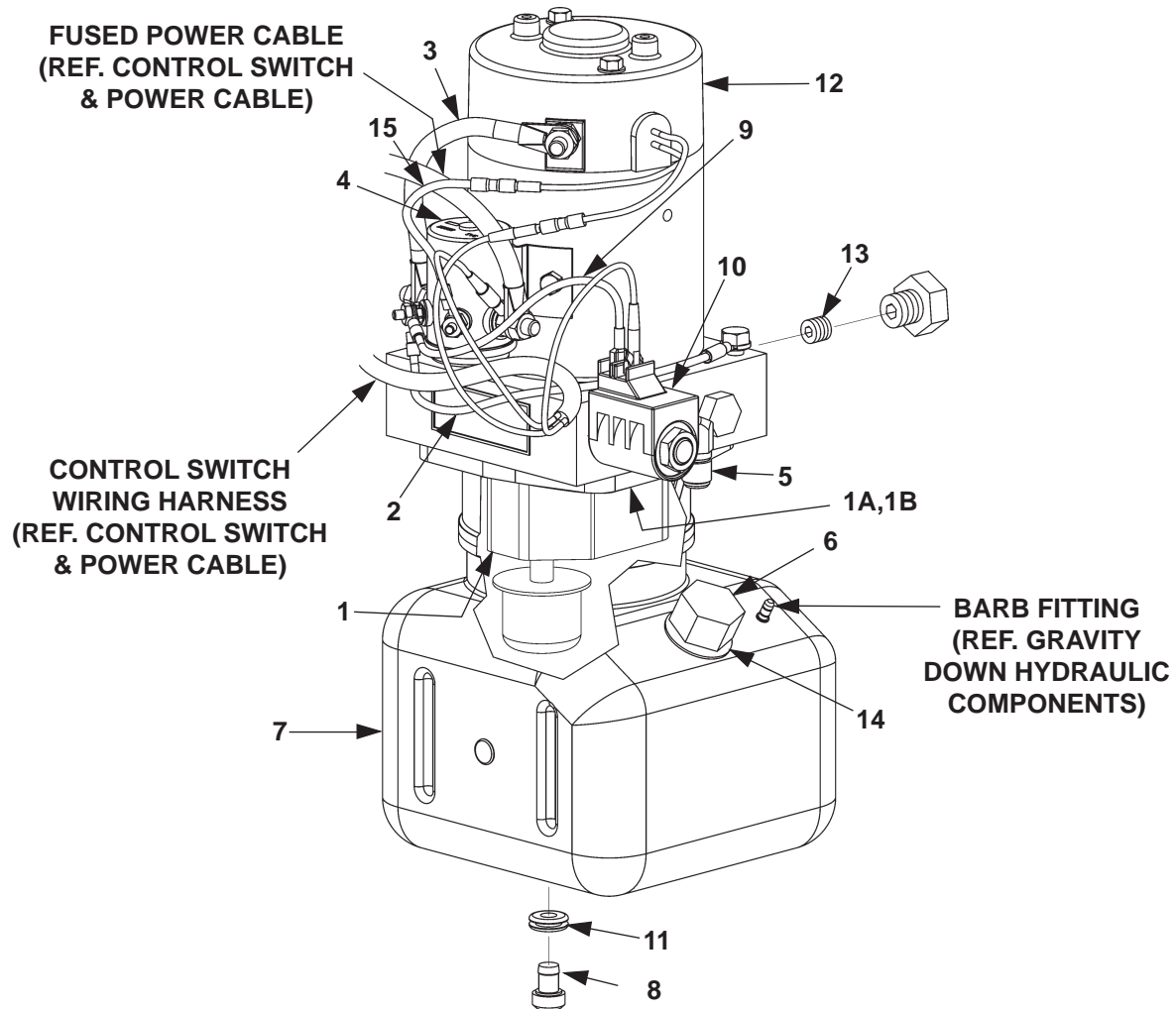

**MAXON**<sup>®</sup>

11921 Slauson Ave. Santa Fe Springs, CA. 90670 (800) 227-4116 FAX (888) 771-7713

ITEM	QTY.	PART NO.	DESCRIPTION
	REF	268070-01	12 VDC POWER UNIT (GRAVITY DOWN)
<b>1</b>	1	290065	3-PIECE GEAR PUMP
<b>1A</b>	1	226594	OIL SEAL KIT
<b>1B</b>	1	290020	O-RING
<b>2</b>	1	268027-01	WIRE ASSEMBLY, 18 GA, #10 RING - 5/16" RING
<b>3</b>	1	280404	CABLE ASSEMBLY
<b>4</b>	1	268029-01	SOLENOID SWITCH
<b>5</b>	1	905152	ELBOW, 90 DEG, O-RING
<b>6</b>	1	280806-01	FILLER CAP
<b>7</b>	1	267733-11	RESERVOIR, 3 QT, VERTICAL WITH VENT
<b>8</b>	1	908017-01	DRAIN PLUG
<b>9</b>	1	280416	WIRE ASSEMBLY
<b>10</b>	1	290043	VALVE ASSEMBLY, 2 WAY
<b>11</b>	1	908018-01	GROMMET, 5/16" I.D.
<b>12</b>	1	280374	MOTOR, 12 VOLT DC
<b>13</b>	1	906737-01	CARTRIDGE RELIEF VALVE
<b>14</b>	1	908016-01	GROMMET, 3/4" I.D.
<b>15</b>	1	268024-01	WIRE ASSY, 16GA WHITE, 3" LG

**MAXON**<sup>®</sup> 11921 Slauson Ave. Santa Fe Springs, CA. 90670 (800) 227-4116 FAX (888) 771-7713

## 24 VDC POWER UNIT (GRAVITY DOWN)

### CAUTION

To prevent damage to starter solenoid, do not over-tighten the terminal nuts. For the 5/16" load terminals, torque nuts 35-40 lbs.-in. Torque the nuts on #10-32 control terminals 15-20 lbs.-in.

### CAUTION

To prevent damage when installing 2-way valves, torque valve cartridge nut to 30 lbs.-in. max.

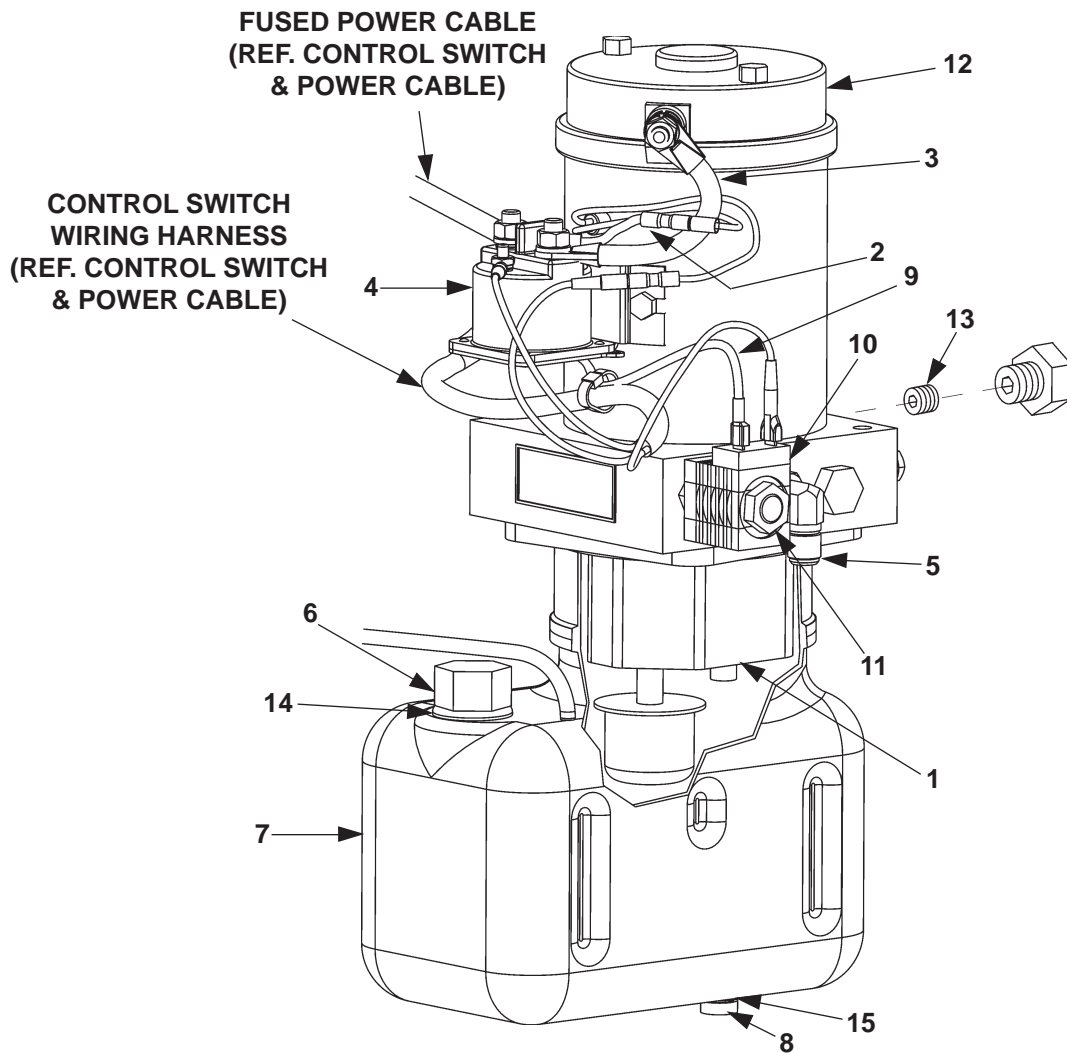

**MAXON**<sup>®</sup>

11921 Slauson Ave. Santa Fe Springs, CA. 90670 (800) 227-4116 FAX (888) 771-7713



ITEM	QTY.	PART NO.	DESCRIPTION
	REF	280610-24	24 VDC POWER UNIT (GRAVITY DOWN)
1	1	290065	3-PIECE GEAR PUMP
2	1	280566-01	WIRE ASSEMBLY, 16 GA, GREEN
3	1	280404	CABLE ASSEMBLY
4	1	281571-01	MOTOR STARTER SOLENOID, 24 VOLT DC
5	1	905152	90 DEG ELBOW
6	1	280806-01	FILLER CAP
7	1	280589-01	RESERVOIR
8	1	908017-01	DRAIN PLUG
9	1	280416	WIRE ASSEMBLY
10	1	281572-01	24 VDC COIL
11	1	906719-01	VALVE
12	1	281573-01	MOTOR, 24 VOLT DC
13	1	906737-01	RELIEF VALVE
14	1	908016-01	GROMMET, 19/32"
15	1	908018-01	GROMMET, 5/16"

**MAXON**<sup>®</sup> 11921 Slauson Ave. Santa Fe Springs, CA. 90670 (800) 227-4116 FAX (888) 771-7713

**MAXON®**

11921 Slauson Ave. Santa Fe Springs, CA. 90670 (800) 227-4116 FAX (888) 771-7713

**THIS PAGE INTENTIONALLY LEFT BLANK**

## POWER DOWN HYDRAULIC COMPONENTS

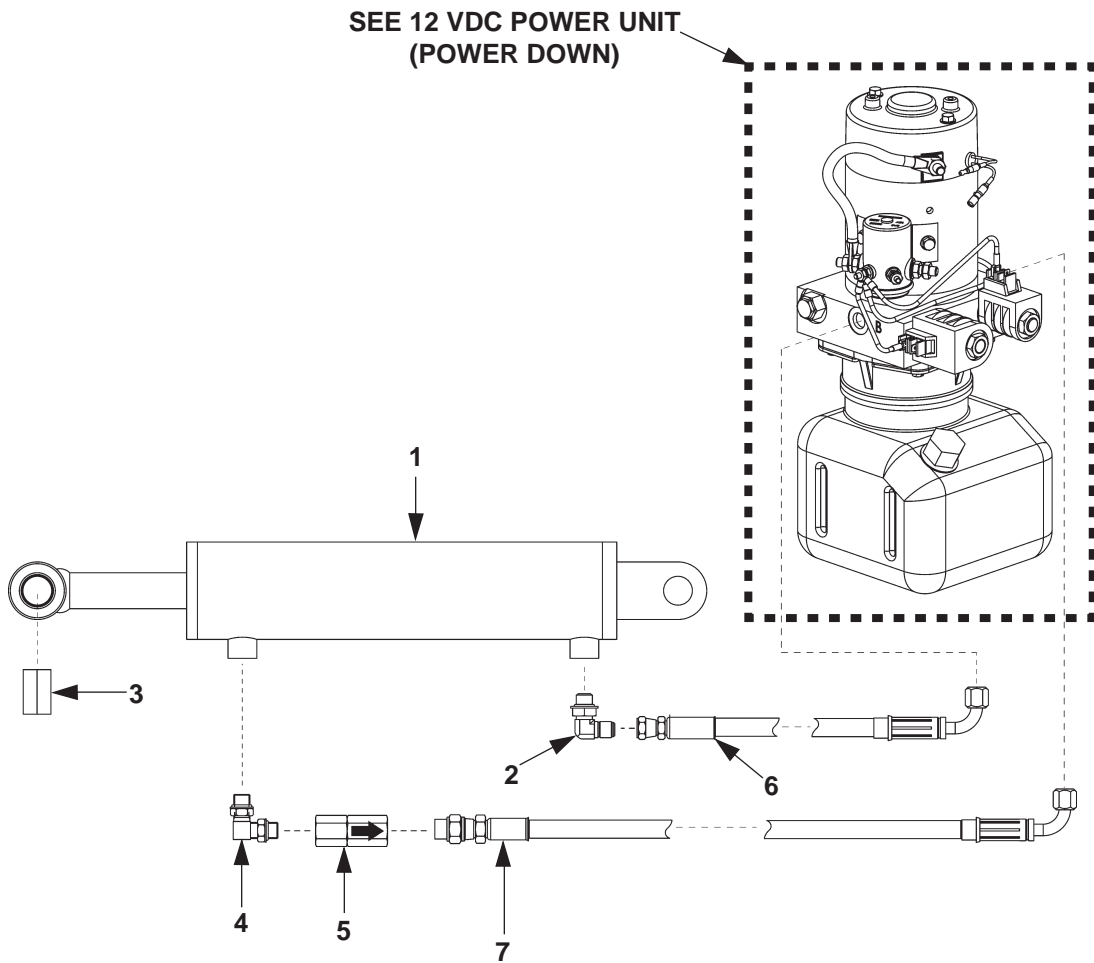

ITEM	QTY.	PART NO.	DESCRIPTION
1	1	266408-01	CYLINDER ASSY, 3-1/2" DIA X 10" STROKE X 1-1/2" ROD DIA (TE-25)
		266401-02	CYLINDER ASSY, 3-1/2" DIA X 10" STROKE X 1-1/4" ROD DIA (TE-25L)
2	1	905152	ELBOW, 90 DEG SAE #6-JIC37 #6
3	1	260916-03	BEARING, SELF LUBE
4	1	906722-01	ELBOW, 90 DEG, O-RING, #6 M-M
5	1	906709-02	FLOW REGULATOR VALVE, 2 GPM
6	1	280635-01	HOSE ASSEMBLY, 3/8"HP, 54"LG.
7	1	280634-01	HOSE ASSEMBLY, 3/8"HP, 50"LG.

**MAXON**<sup>®</sup> 11921 Slauson Ave. Santa Fe Springs, CA. 90670 (800) 227-4116 FAX (888) 771-7713

## 12 VDC POWER UNIT (POWER DOWN)

### CAUTION

To prevent damage to metal case starter solenoid, hold bottom terminal nut securely when loosening and tightening top terminal nut. Do not over-tighten the terminal nuts. For the 5/16" load terminals, torque nuts 35-40 lbs.-in. Torque the nuts on #10-32 control terminals 15-20 lbs.-in.

### CAUTION

To prevent damage when installing 2-way valves, torque valve cartridge nut to 30 lbs.-in. max.

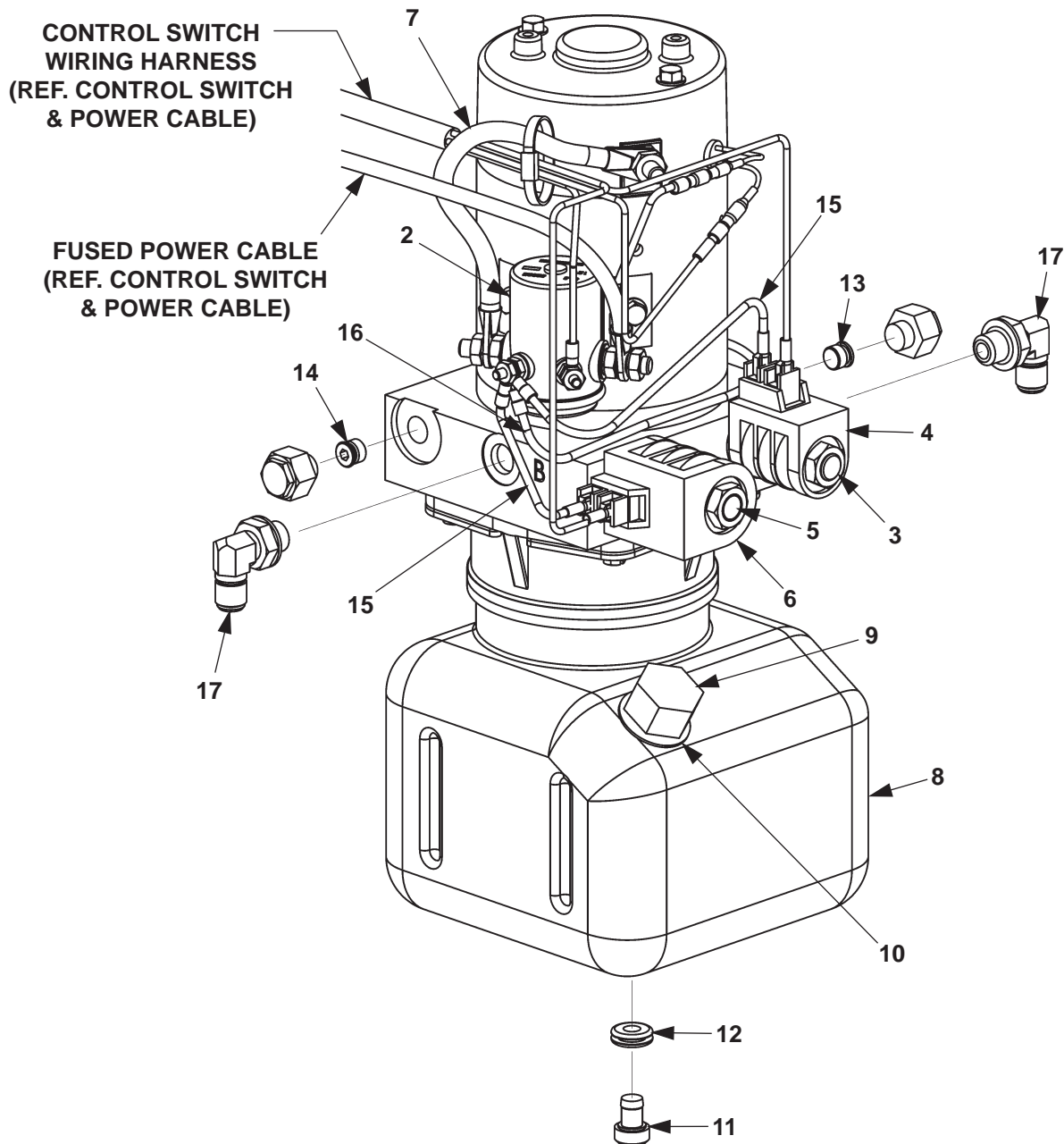

**MAXON**<sup>®</sup>

11921 Slauson Ave. Santa Fe Springs, CA. 90670 (800) 227-4116 FAX (888) 771-7713

ITEM	QTY	PART NO.	DESCRIPTION
	REF	268181-01	12 VDC POWER UNIT (POWER DOWN)
1	1	268176-01	MOTOR, 12 VDC
2	1	268029-01	SWITCH, SOLENOID
3	1	290044	VALVE CARTRIDGE, DOUBLE SPADE
4	1	290045	COIL, DOUBLE SPADE, 2 WAY
5	1	290047	VALVE CARTRIDGE, 4 WAY
6	1	290048	COIL, DOUBLE SPADE, 4 WAY
7	1	280404	CABLE ASSEMBLY
8	1	267733-01	RESERVOIR, 3 QT, VERTICAL
9	1	280806-01	FILLER CAP
10	1	908016-01	GROMMET, 3/4" I.D.
11	1	908017-01	DRAIN PLUG
12	1	908018-01	GROMMET, 5/16" I.D.
13	1	906738-02	RELIEF VALVE, ADJUST, 3200PSI
14	1	268174-01	RELIEF VALVE, ADJUST, 1100PSI
15	2	280416	WIRE ASSEMBLY
16	1	268027-01	WIRE ASSEMBLY, 18 GA, #10 RING - 5/16" RING
17	2	905152	ELBOW, 90 DEG, O-RING

**MAXON**

11921 Slauson Ave. Santa Fe Springs, CA. 90670 (800) 227-4116 FAX (888) 771-7713

### DECALS



**WARNING DECAL**  
(2 PLACES, LH SIDE NOT SHOWN)  
P/N 265736-03

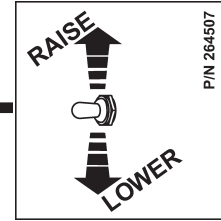

**RAISE/LOWER DECAL**  
P/N 264507

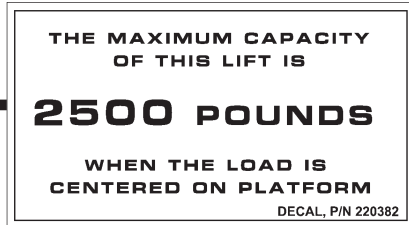

**CAPACITY DECAL**  
P/N 220382

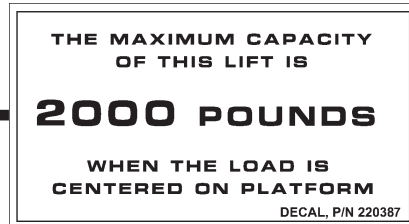

**CAPACITY DECAL**  
(SPECIAL LIFTGATES ONLY)  
P/N 220387

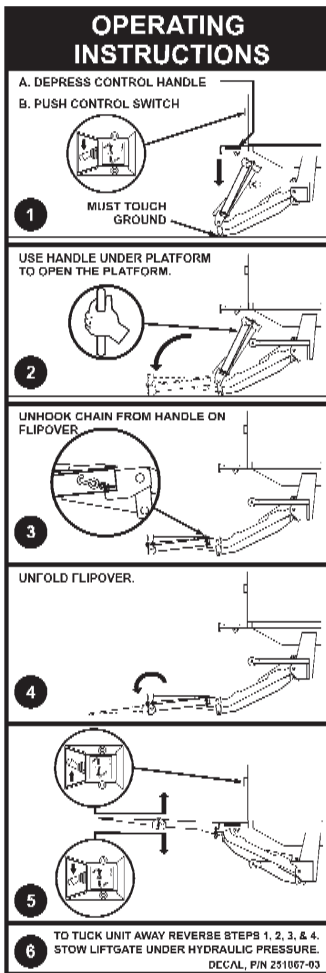

**INSTRUCTION DECAL**  
P/N 251867-03

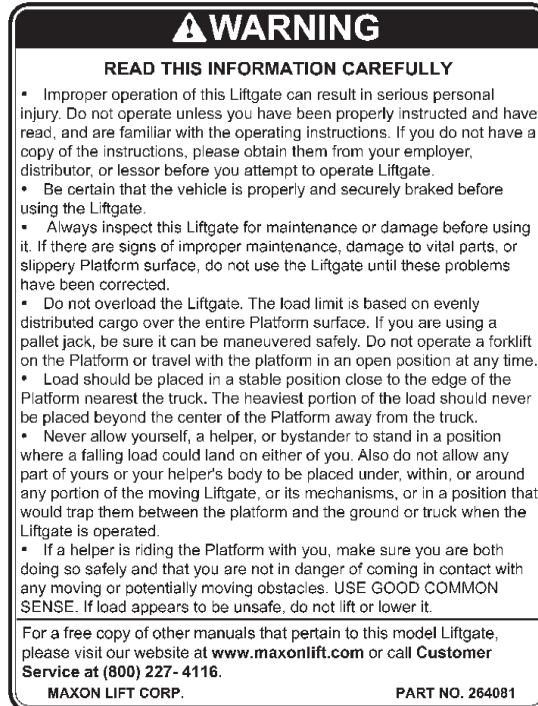

**WARNING DECAL**  
P/N 264081

**FIG. 38-1**

## CONTROL SWITCH AND POWER CABLE

**NOTE:** Use switch to **RAISE** and **LOWER** Liftgate to make sure switch operates as shown on the decal.

**NOTE:** MAXON recommends using dielectric grease on all electrical connections.

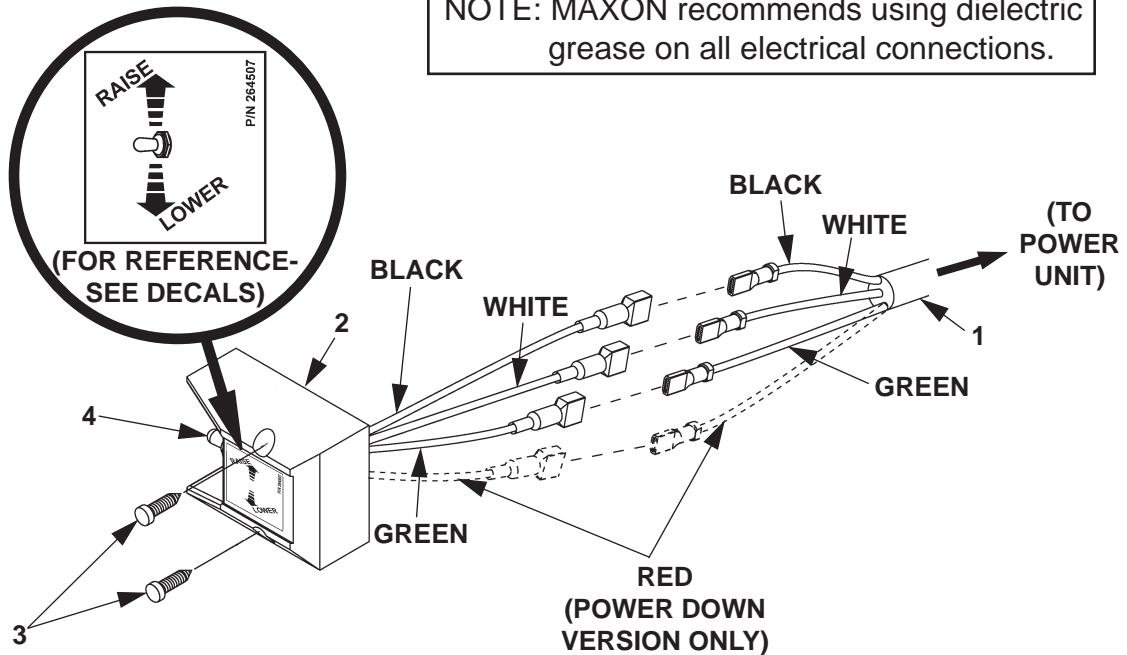

ITEM	QTY.	PART NO.	DESCRIPTION
1	1	268025-01	CABLE ASSEMBLY, 84" LG (12 VDC GRAVITY DOWN)
		280637-01	CABLE ASSEMBLY, 84" LG (24 VDC GRAVITY DOWN)
		268170-01	CABLE ASSEMBLY, 85" LG (POWER DOWN)
2	1	267959-01	MOLDED SWITCH ASSEMBLY (GRAVITY DOWN)
		264951-04	MOLDED SWITCH ASSEMBLY (POWER DOWN)
3	2	900057-5	SCREW, SELF-TAPPING #10-24 X 1" LG.
4	1	905206	SWITCH BOOT SEAL
5	1	264422	CABLE ASSEMBLY, 200 AMPS, 38' LG
6	1	264687	KIT, MEGAFUSE (200 AMP FUSE & HEATSHRINK TUBING)

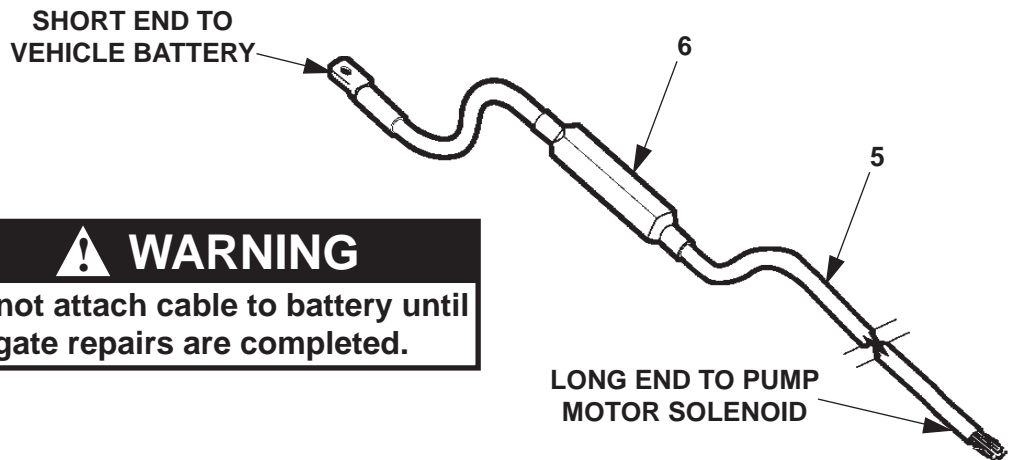

**⚠ WARNING**

Do not attach cable to battery until Liftgate repairs are completed.

**MAXON** 11921 Slauson Ave. Santa Fe Springs, CA. 90670 (800) 227-4116 FAX (888) 771-7713

# HYDRAULIC SYSTEM DIAGRAMS

## HYDRAULIC SCHEMATIC (GRAVITY DOWN)

**MAXON**<sup>®</sup>

11921 Slauson Ave. Santa Fe Springs, CA. 90670 (800) 227-4116 FAX (888) 771-7713

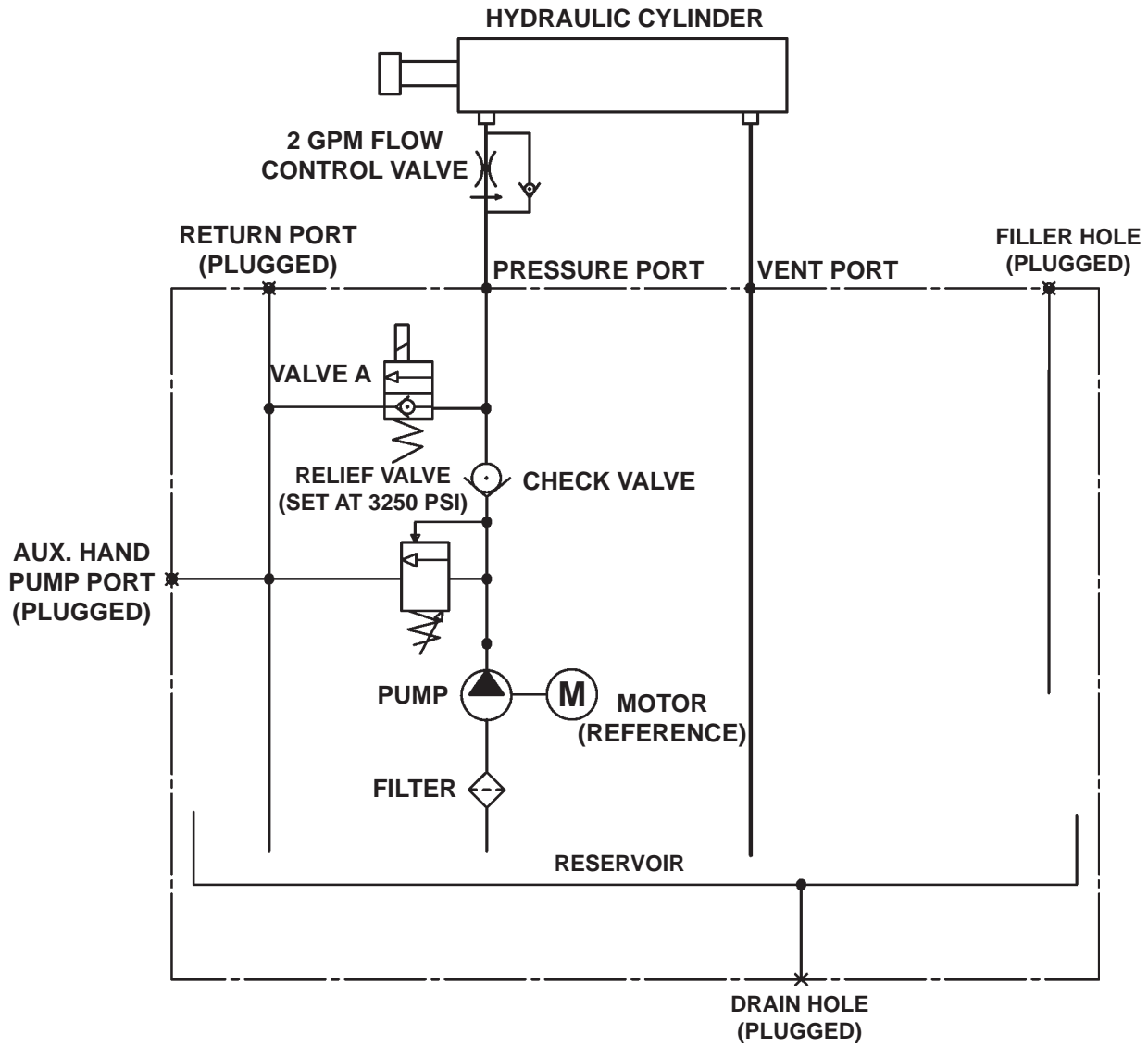



# HYDRAULIC SCHEMATIC (POWER DOWN)

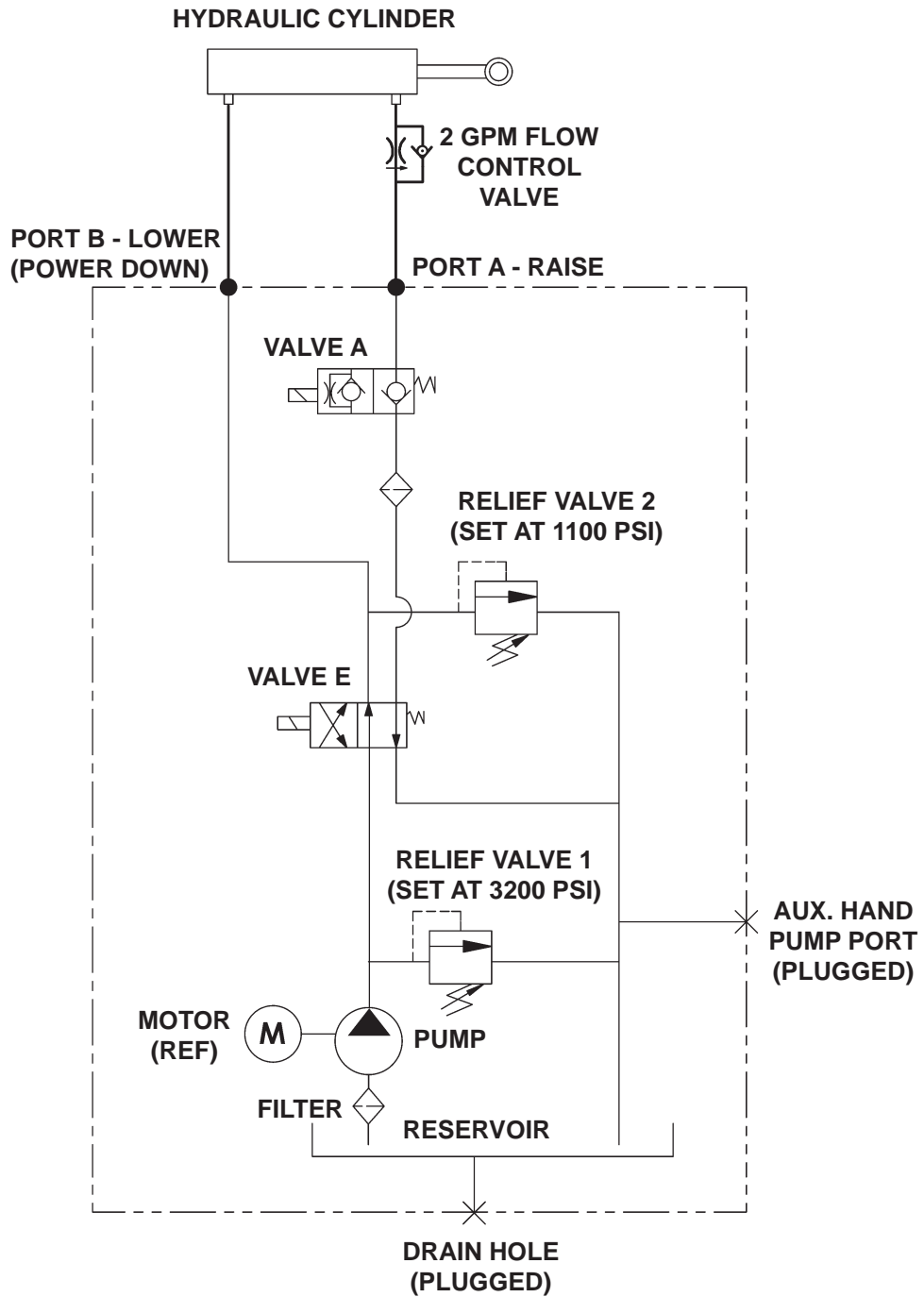

# ELECTRICAL SYSTEM DIAGRAMS

## ELECTRICAL SCHEMATIC (GRAVITY DOWN)

**MAXON**<sup>®</sup>

11921 Slauson Ave. Santa Fe Springs, CA. 90670 (800) 227-4116 FAX (888) 771-7713

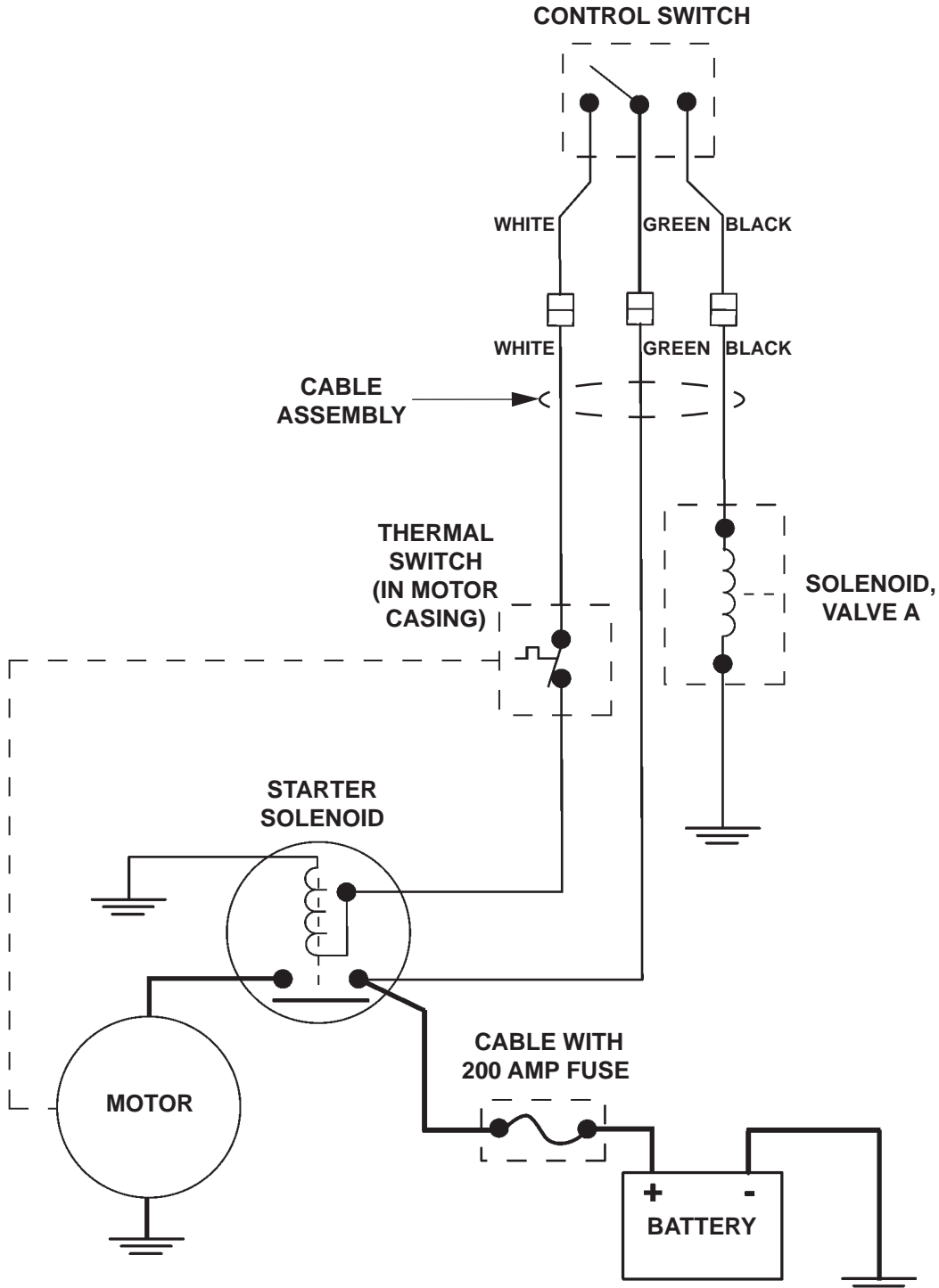

# ELECTRICAL SCHEMATIC (POWER DOWN)

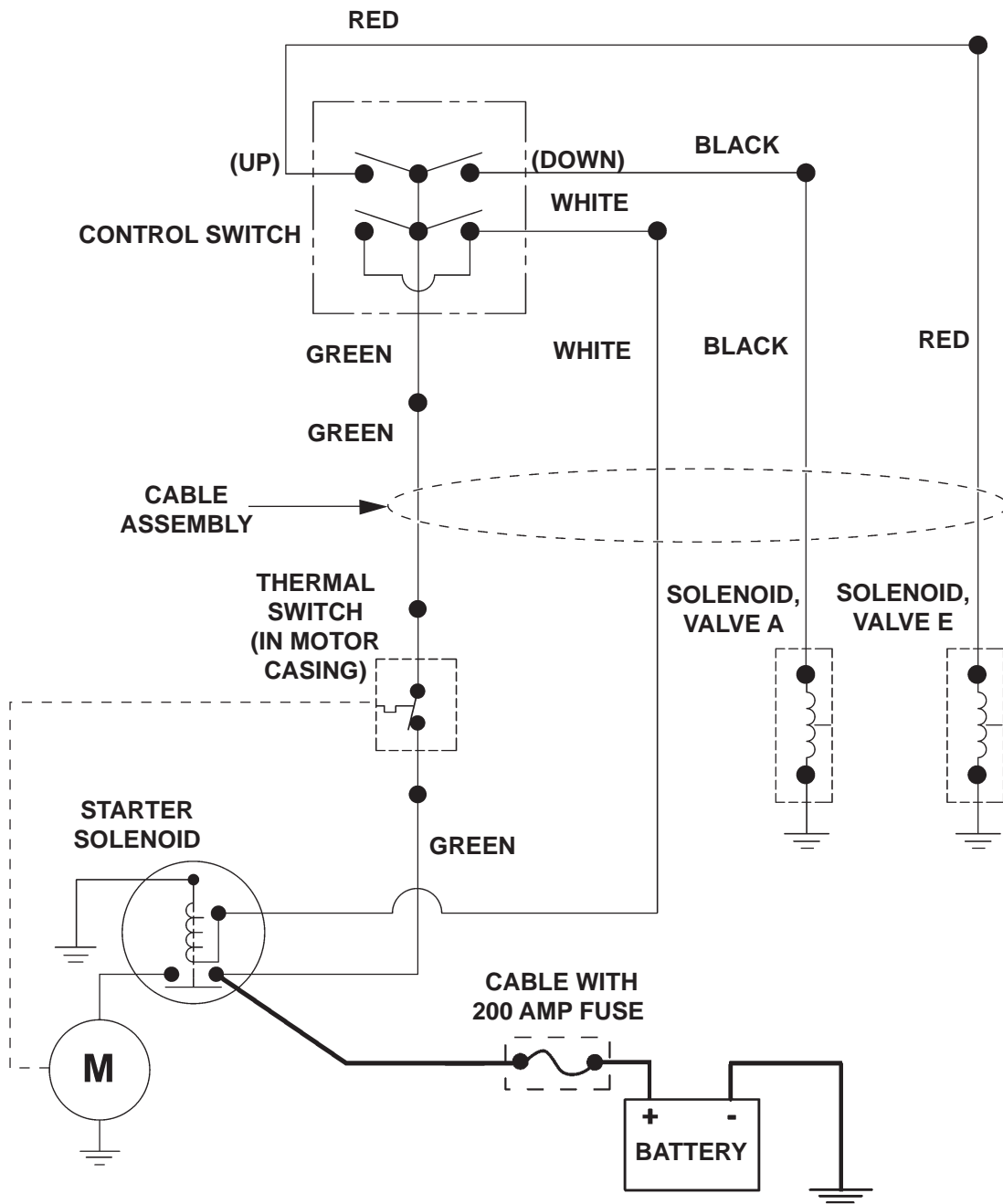

# TROUBLESHOOTING

## PLATFORM WILL NOT RAISE

1. Use voltmeter to verify power is being supplied to solenoid terminal "B" (FIG. 44-1). Recharge the battery if there is less than 12.6 volts.

### CAUTION

Keep dirt, water and other contaminants from entering the hydraulic system. Before opening the hydraulic fluid reservoir filler cap, drain plug and hydraulic lines, clean up contaminants that can get in the openings. Also, protect the openings from accidental contamination during maintenance.

2. See the **CHECKING HYDRAULIC FLUID** procedure. If necessary, add hydraulic fluid.
3. Touch a jumper wire to terminals "B" & "D" (FIG. 44-1). If motor runs, check switch, switch connections, and white wire. Check and correct wiring connections or replace the switch.
4. Touch heavy jumper cables to terminals "A" & "B" (FIG. 44-1).
  - a. If motor runs, replace the motor solenoid.
  - b. If motor does not run, repair or replace the pump motor.

**NOTE:** In most cases, you can avoid having to manually bleed hydraulic system by correctly positioning Liftgate platform before disconnecting any lifting cylinder high pressure hydraulic lines. The following procedure can save time and prevent accidental fluid spills and hazards.

5. Check for structural damage and replace worn parts.
6. Check filter in the pump reservoir. Replace filter if necessary.
7. Check for dirty pump motor relief valve. Clean if necessary. Replace any worn out relief valve parts.

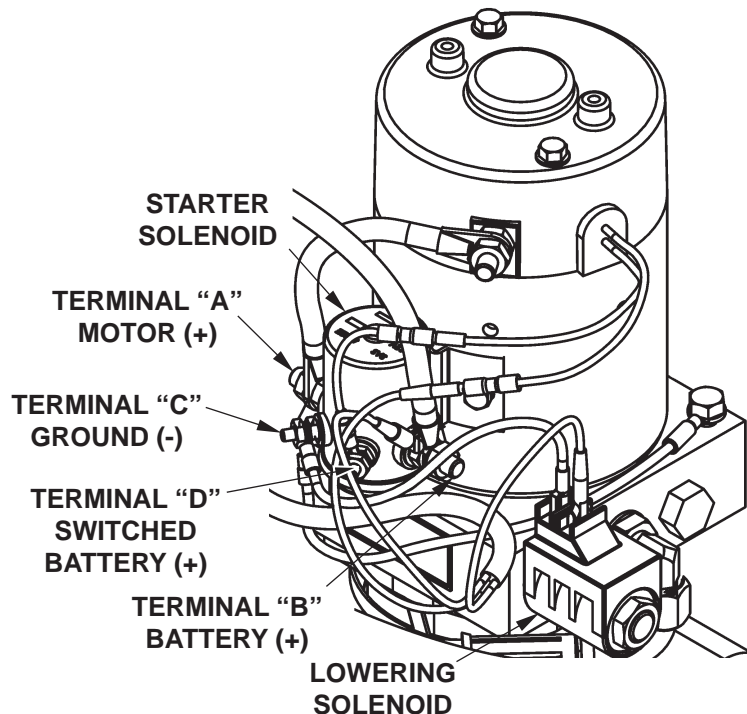

FIG. 44-1

## PLATFORM RAISES BUT LEAKS DOWN

1. Check if solenoid valves are constantly energized by touching a screwdriver to the top nut of the solenoid (**FIG. 45-1**). Try pulling the screwdriver away from the solenoid. If the solenoid nut attracts the screwdriver (magnetically) without pushing the toggle switch, the control circuit is operating incorrectly. Check if toggle switch, wiring or coil are faulty.

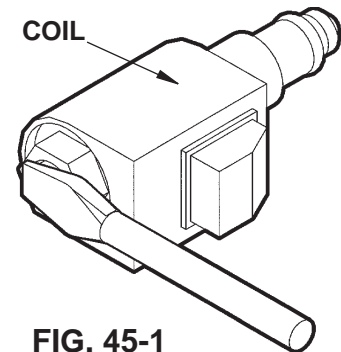

FIG. 45-1

### CAUTION

Keep dirt, water and other contaminants from entering the hydraulic system. Before opening the hydraulic fluid reservoir filler cap, drain plug and hydraulic lines, clean up contaminants that can get in the openings. Also, protect the openings from accidental contamination during maintenance.

**NOTE:** In most cases, you can avoid having to manually bleed hydraulic system by correctly positioning Liftgate platform before disconnecting any lifting cylinder high pressure hydraulic lines. The following procedure can save time and prevent accidental fluid spills and hazards.

2. Check the valve stem by removing the coil assembly (**Item 1, FIG. 45-2**). With platform on ground, unscrew the valve stem (**Item 2, FIG. 45-2**) from the pump. Push on the plunger that is located inside the valve stem by inserting a small screwdriver blade in the end. If the plunger does not move freely, (approximately 1/8") replace the valve stem. **When reinstalling valve stem, torque hex nut to 30 in-lbs.**

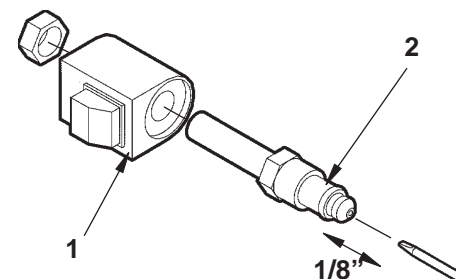

FIG. 45-2

3. Check the hydraulic cylinder. With the platform on the ground, remove the hydraulic line from the vent/down port of the cylinder (**FIG. 45-3**). Raise the platform even with the bed. Allow pump motor to run two seconds more while you watch for hydraulic fluid at the vent/down port. A few drops of hydraulic fluid escaping the vent/down port is normal; however, if it streams from the vent/down port, piston seals are worn. Replace seals.

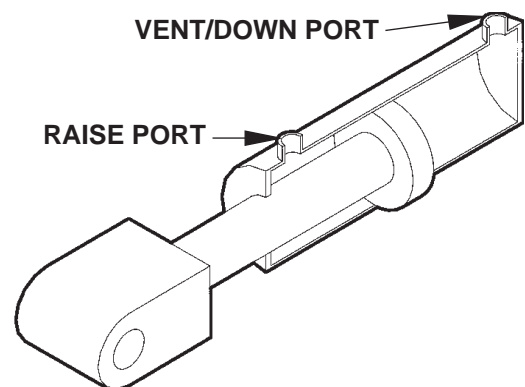

FIG. 45-3

# TROUBLESHOOTING

## PLATFORM RAISES PARTIALLY AND STOPS

### CAUTION

Keep dirt, water and other contaminants from entering the hydraulic system. Before opening the hydraulic fluid reservoir filler cap, drain plug and hydraulic lines, clean up contaminants that can get in the openings. Also, protect the openings from accidental contamination during maintenance.

1. See the **CHECKING HYDRAULIC FLUID** procedure. If necessary, add hydraulic fluid.
2. Use voltmeter to verify the battery shows 12.6 volts or more.
3. Check for structural damage and poor lubrication. Replace worn parts.

**NOTE:** In most cases, you can avoid having to bleed the hydraulic system by correctly positioning Liftgate platform before opening hydraulic lines. Refer to following procedure. Save time on the job and prevent accidental fluid spills and hazards.

4. Check the hydraulic cylinder. With the platform on the ground, remove the breather plug or vent line from the vent/down port of the cylinder (**FIG. 46-1**). Raise the platform even with the bed. Allow pump motor to run two seconds more while you watch for hydraulic fluid at the vent/down port. A few drops of hydraulic fluid escaping the vent/down port is normal; however, if it streams from the vent/down port, piston seals are worn. Replace seals.
5. Check filter in the pump reservoir. Replace filter if necessary.
6. Check for dirty pump motor relief valve. Clean if necessary. Replace any worn out relief valve parts.

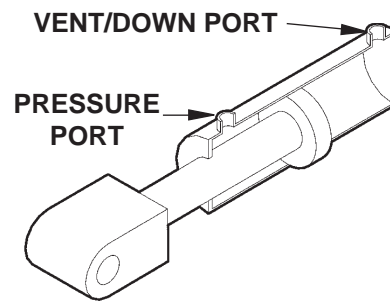

**FIG. 46-1**

**MAXON**

11921 Slauson Ave. Santa Fe Springs, CA. 90670 (800) 227-4116 FAX (888) 771-7713

## LIFTGATE WILL NOT LIFT RATED CAPACITY

1. Use voltmeter to verify the battery shows 12.6 volts or more under load from pump motor.
2. Check for structural damage and lack of lubrication. Replace worn parts.

### CAUTION

Keep dirt, water and other contaminants from entering the hydraulic system. Before opening the hydraulic fluid reservoir filler cap, drain plug and hydraulic lines, clean up contaminants that can get in the openings. Also, protect the openings from accidental contamination during maintenance.

**NOTE:** In most cases, you can avoid having to bleed the hydraulic system by correctly positioning Liftgate platform before opening hydraulic lines. Refer to following procedure. Save time on the job and prevent accidental fluid spills and hazards.

3. With platform on the ground, remove the pressure hose and fitting from the pump and replace it with a 0-4000 PSI pressure gauge. Hold the switch in the "UP" position. Adjust the relief valve on the side of the pump until the gauge shows 3250 PSI (**FIG. 47-2**). Remove gauge and reinstall pressure hose.
4. Check for dirty pump motor relief valve. Clean if necessary. Replace any worn out relief valve parts.
5. Check the hydraulic cylinder. With the platform on the ground, remove the breather plug or vent line from the vent/down port of the cylinder (**FIG. 47-1**). Raise the platform even with the bed. Allow pump motor to run two seconds more while you watch for hydraulic fluid at the vent/down port. A few drops of hydraulic fluid escaping the vent/down port is normal; however, if it streams from the vent/down port, piston seals are worn. Replace seals.
6. If pump cannot produce 3250 PSI can't lift load capacity with a minimum of 12.6 volts available, the pump is worn and needs to be replaced.

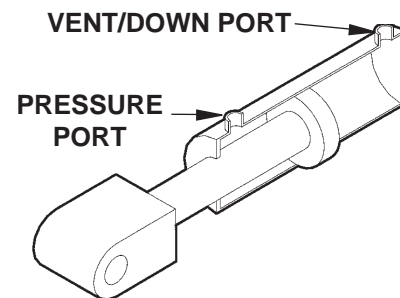

FIG. 47-1

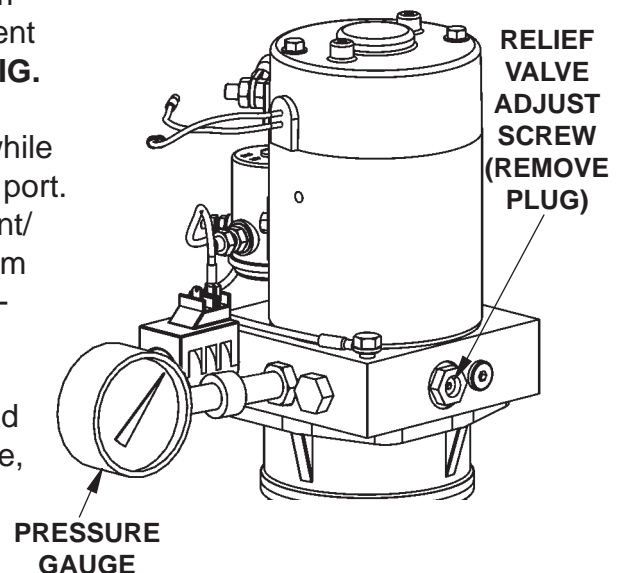
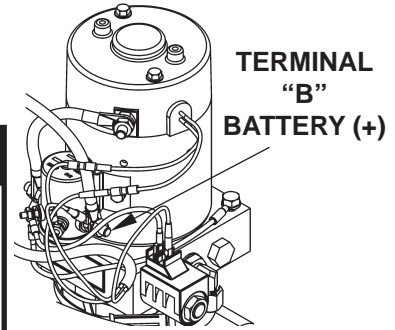

FIG. 47-2

# TROUBLESHOOTING PLATFORM RAISES SLOWLY

1. Use voltmeter to verify power is being supplied to solenoid terminal "B". Recharge the battery if voltmeter indicates less than 12.6 volts (FIG. 48-1).



**FIG. 48-1**

## CAUTION

Keep dirt, water and other contaminants from entering the hydraulic system. Before opening the hydraulic fluid reservoir filler cap, drain plug and hydraulic lines, clean up contaminants that can get in the openings. Also, protect the openings from accidental contamination during maintenance.

2. Check the hydraulic cylinder. With the platform on the ground, remove the breather plug or vent line from the vent/down port of the cylinder (FIG. 48-3). Raise the platform even with the bed. Allow pump motor to run two seconds more while you watch for hydraulic fluid at the vent/down port. A few drops of hydraulic fluid escaping the vent/down port is normal; however, if it streams from the vent/down port, piston seals are worn. Replace seals.

**NOTE:** In most cases, you can avoid having to bleed the hydraulic system by correctly positioning Liftgate platform before opening hydraulic lines. Refer to following procedure. Save time on the job and prevent accidental fluid spills and hazards.

3. Check and clean flow control valve in high pressure hydraulic line attached to cylinder. When installing flow control valve, make sure arrow on valve is oriented as shown in FIG. 48-3.

4. See the **CHECKING HYDRAULIC FLUID** procedure. If necessary, add hydraulic fluid.

5. Verify the pump motor is grounded to the vehicle frame.

6. Check for leaking hoses and fittings. Tighten or replace as required.

7. Check for structural damage or poor lubrication. Replace worn parts.

8. Check the filter in the pump reservoir. Replace if necessary.

9. With platform on the ground, remove the pressure hose and fitting from the pump and replace it with a 0-4000 PSI pressure gauge. Hold the control switch in the "RAISE" position. Adjust the relief valve on the side of the pump until the gauge shows 3250 PSI (FIG. 48-2). Remove gauge and reinstall pressure hose.

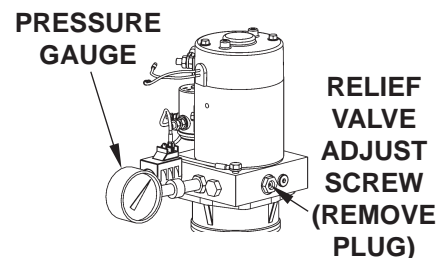

**FIG. 48-2**

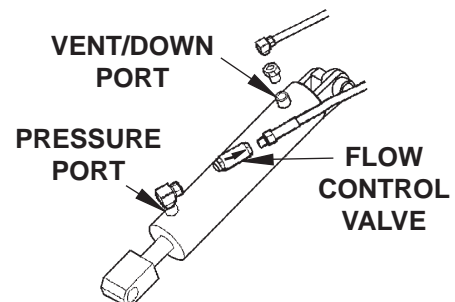
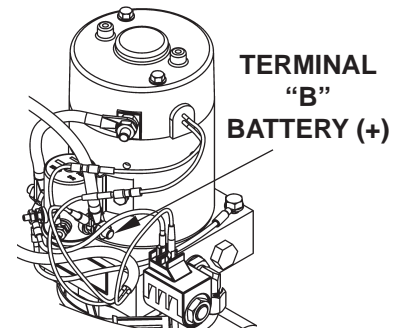

**FIG. 48-3**



## PLATFORM WILL NOT LOWER, LOWERS TOO SLOWLY OR TOO QUICKLY

1. Use voltmeter to verify power is being supplied to solenoid terminal "B". Recharge the battery if voltmeter displays less than 12.6 volts (**FIG. 49-1**).
2. Check for structural damage or poor lubrication. Replace worn parts.
3. Check if solenoid valve is getting power by holding a screwdriver against the top nut of the solenoid. Push control switch to "**LOWER**" position to energize solenoid (**FIG. 49-2**). A good solenoid will attract (magnetically) the screwdriver to the nut and make it difficult to pull the screwdriver away from the nut.



**FIG. 49-1**

### CAUTION

Keep dirt, water and other contaminants from entering the hydraulic system. Before opening the hydraulic fluid reservoir filler cap, drain plug and hydraulic lines, clean up contaminants that can get in the openings. Also, protect the openings from accidental contamination during maintenance.

**NOTE:** In most cases, you can avoid having to bleed the hydraulic system by correctly positioning Liftgate platform before opening hydraulic lines. Refer to following procedure. Save time on the job and prevent accidental fluid spills and hazards.

4. Check the valve stem by removing the coil assembly (**Item 1, FIG. 49-2**). With platform supported, unscrew the valve stem (**Item 2, FIG. 49-2**) from the pump. Push on the plunger located inside the valve stem by inserting a small screwdriver blade in the end. If the plunger does not move freely (approximately 1/8"), replace the valve stem.
5. Check if filtering screen on solenoid valve is plugged. Clean carefully if required.
6. Check and clean flow control valve in high pressure hydraulic line attached to cylinder.
7. Check if flow control valve (**FIG. 49-3**) is pointing to the direction of restricted fluid flow (back toward pump). If required, remove flow control valve and install it correctly (**FIG. 49-3**).

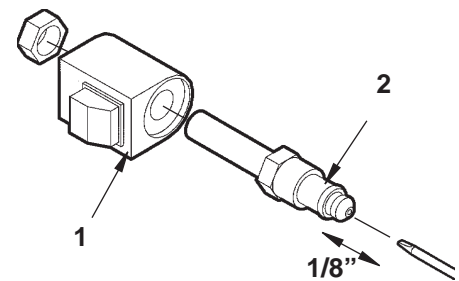

**FIG. 49-2**

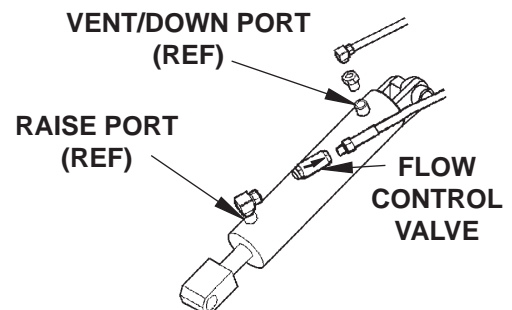

**FIG. 49-3**

