

ROTARY TABLES

Ideal for Bottle Unscrambling, Accumulating and Surge Back-Up



Unscrambling Table with Standard
Stainless Steel Loading Table
Model FS-U-48



Unscrambling
Table
Model FS-U-36

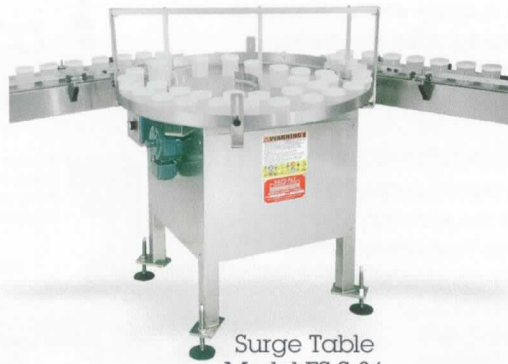

Surge Table
Model FS-S-36



Accumulating Table
Model FS-A-48
Shown with
Kaps-All Capper

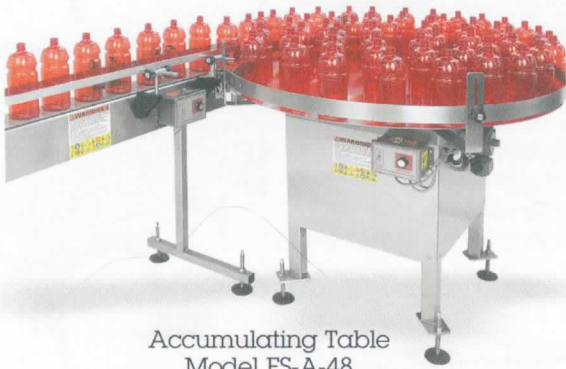

Accumulating Table
Model FS-A-48



Model AU-3



Model AU-6

Also Available:
Fully Automatic Bottle Unscramblers and Cleaners
Ask for literature and a quote on our Automatic Models

FEATURES:

- Fast Changeovers
- Handles vials to gallons of all materials
- 36" and 48" stainless steel tops
- Electronic variable speed drives
- Clockwise and counterclockwise orientation
- Ideal for all industries
- Fast delivery
- 2 year guarantee — the longest in the industry

The Proven Standard@...Since 1941

**KAPS-ALL
PACKAGING SYSTEMS INC.**

KAPS-ALL CAPPER®
FEED SYSTEMS®

FILLS-ALL®
ORIENTAINER®

200 Mill Road, Riverhead, NY 11901 USA

Tel: 631-727-0300 ▪ Fax: 631-369-5939

www.kapsall.com

Rotary Tables for Bottle Unscrambling, Accumulating and Surge Back-up



SPECIFICATIONS and FEATURES:

- 36" and 48" diameter stainless steel table tops standard
- Stainless steel rails and guard covers standard
- No change parts required for all standard bottles and jars
- Stainless steel elevating screws with floor pads provided
- Stainless steel outer guide rails adjust to accommodate vials to gallon containers without tools
- Electronically controlled variable speed motor with gear box
- No skilled personnel required
- Stainless steel unloading tables (standard for unscramblers)
- Heavy-duty rugged construction • Fast delivery
- Two full year guarantee — the longest in the industry

OPTIONS:

- Stainless steel inner frame
- Stainless steel pack-off tables for accumulating table Model FS-A
- Stainless steel transfer plates for rotary table to conveyor
- Swivel casters for portability
- Orienting wheels for square, rectangular and oval containers
- Hazardous location models available
- Fully automatic bottle unscramblers (Ask for more information)
- Custom applications tailored to your exact needs including packoff/work conveyors and multi-lane tables
- Complete line of conveyors available to suit your needs

Rotary table/conveyor layouts:

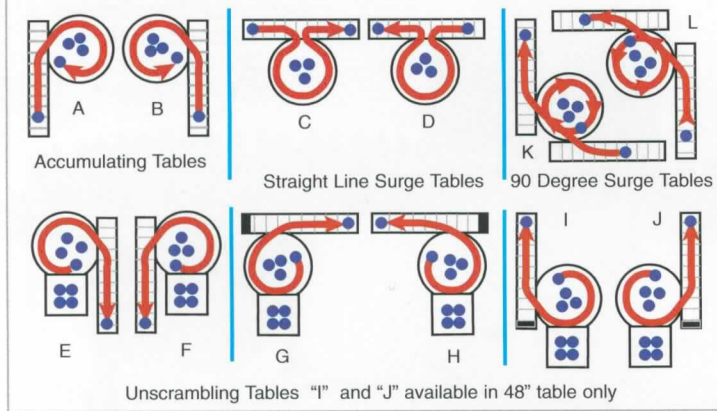

Dimensions for 36" and 48" diameter Rotary Tables

Electrical Requirements: 110VAC, 1 Phase, 50/60 Hz, 3.2 amps

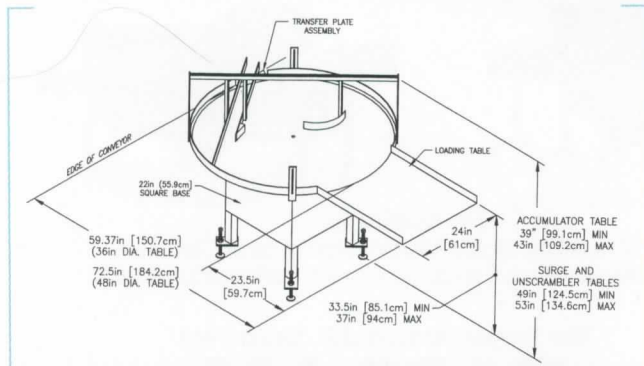

Note: Due to Kaps-all Packaging Systems commitment to maintain quality leadership in the packaging industry, dimensions and specifications are subject to change without notice.

Developers and Manufacturers of Complete Bottling and Packaging Systems

- KAPS-ALL® Bottle Cappers and Cap Tighteners • FILLS-ALL® Rotary and Straight Line Automatic/Semi-Automatic Liquid Fillers • FEED SYSTEMS® Rotary and Escalator Parts Feeders • CLEAN-N-VAC® Bottle Cleaners • ORIENTAINER® Bottle Orienters and Unscramblers • CONVEYS-ALL® Conveying Systems • EASY-KAP® Hand Cappers • Ball Placers • Bulk Loaders • Accumulators • Bottle Carriers • Desiccant Inserters • Electronic Torque Metering and Monitoring • Heat Induction Waterless Cap Sealer® • Inspection Systems, Detects and Rejects Defects® • Custom Packaging Machinery

Kaps-All Packaging Systems, Inc., 200 Mill Road, Riverhead, NY 11901-3125 USA • Tel: 631-727-0300 • Fax: 631-369-5939 • www.kapsall.com

© COPYRIGHT 2006 KAPS-ALL PACKAGING SYSTEMS, INC. • US AND FOREIGN PATENTS, OTHERS PENDING • BULLETIN 11/06

Rotary Unscrambling Tables:

The Rotary Unscrambling Table is designed to unscramble round bottles, jars, cans and containers.

From the stainless steel feed table, the containers are transferred onto the stainless steel rotary disc for orienting. They are then single-filed and discharged onto a conveyor to the next downstream operation. This design ensures the removal of all containers without manual assistance. Many non-round containers can be accommodated with optional tooling.



Model FS-U-48 Unscrambler

Rotary Surge Tables:

The Rotary Surge Table provides a container accumulation area in the event of a backup or stoppage down the line. It is designed to fit into both existing and new conveyor lines. This enables the line to continue running while the backup is being cleared. After the backup is cleared, the surge table will then single file the containers and feed them back onto the conveyor automatically.



Model FS-S-36 Surge Table

Rotary Accumulating Tables:

The Rotary Accumulating Table is placed at the end of a conveyor line to receive bottles, jars, cans or containers after they have passed through cleaning, filling and capping operations. The accumulating table prevents slowdowns in previous operations because it quickly and completely removes items from the conveyor. An optional pack-off table is available. Custom assembly pack-off conveyors built to suit your exact needs.

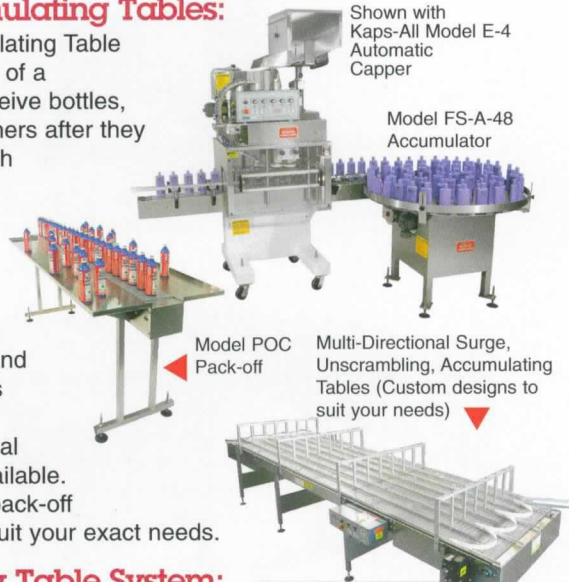

Shown with Kaps-All Model E-4 Automatic Capper

Model FS-A-48 Accumulator

Model POC Pack-off Multi-Directional Surge, Unscrambling, Accumulating Tables (Custom designs to suit your needs)

Typical Rotary Table System:

