

**Fast and Easy Changeovers — Requiring No Change Parts**

**Fully Automatic • 8 Spindle • Medium To High Speed • Portable • 2 Year Guarantee**

# KAPS-ALL® CAPPER

## EXCLUSIVE KAPS-ALL FEATURES:

- Caps Containers Of All Heights, Widths, Shapes And Materials
- Handles All Types Of Caps Including Child Resistant, Pilfer Evident And Snap-On
- Patented, Award-Winning Designs And Features
- No Universal Joints — Minimal Moving Parts
- Available In 4, 6 or 8 Spindle Models For All Applications And Speeds
- 2 Year Guarantee — The Longest In The Industry

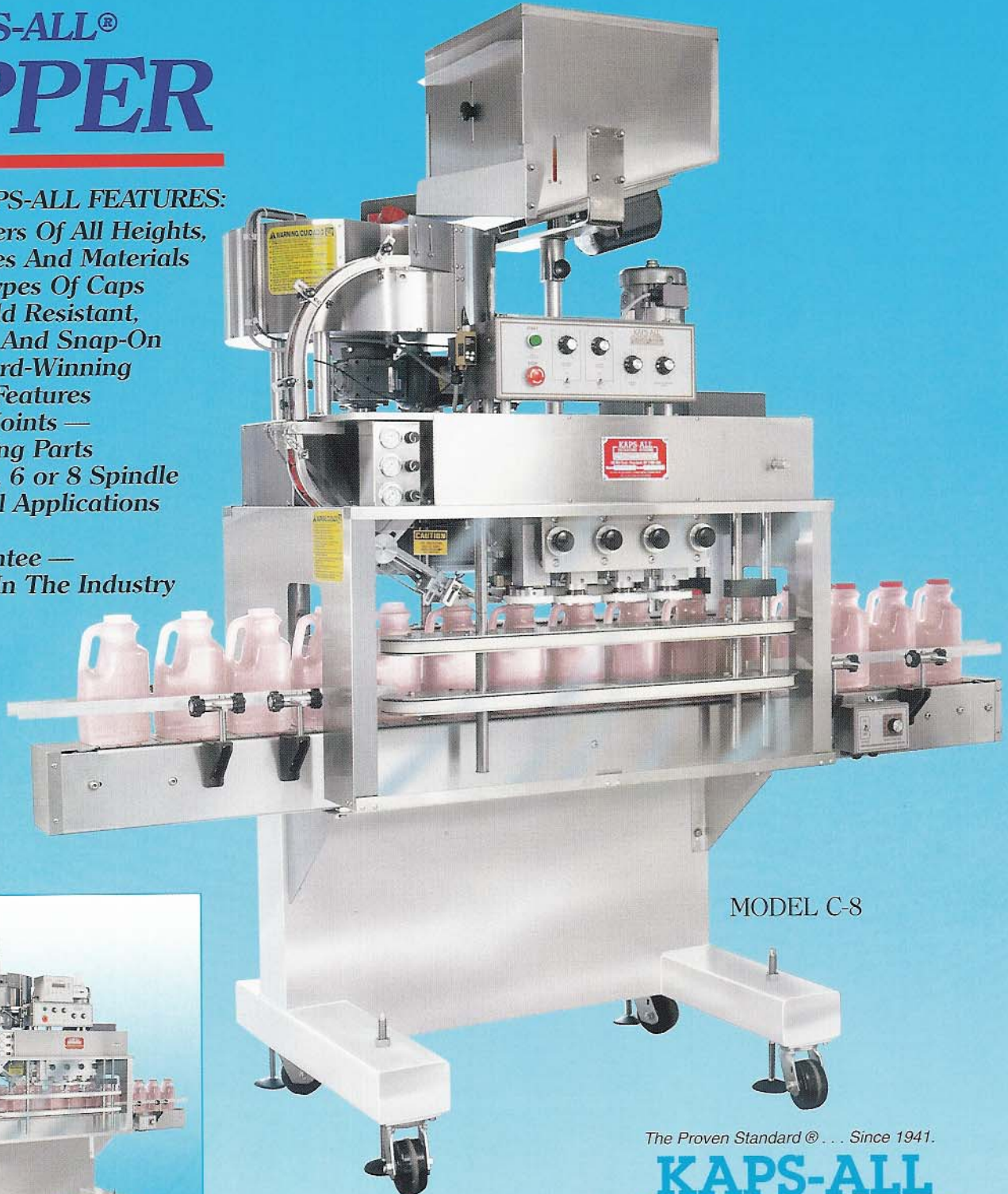

MODEL C-8



Available with optional Parts Elevator (shown) or Parts Escalator/Orienter/Feeder (not shown) both featuring waist-level loading.

The Proven Standard © . . . Since 1941.

**KAPS-ALL**  
**PACKAGING SYSTEMS INC.**  
KAPS-ALL CAPPER®      FILLS-ALL®  
FEED SYSTEMS®      ORIENTAINER®

200 Mill Road, Riverhead, NY 11901-3125 USA  
TEL (516) 727-0300 • FAX (516) 369-5939





# 8 Spindle, Medium To High Speed Portable Capper

## Additional Features:

- No changeover parts are necessary, only knob adjustments with calibrated settings for fast changeovers of virtually any size and shape container from vials to 2-1/2 gallons.
- Standard stainless steel components throughout include: stainless steel upper and lower cap chutes, stainless steel cap supply hopper, stainless steel upper guarding, stainless steel bottle gripper housing, stainless steel conveyor frame, stainless steel shafting, stainless steel cap feeder, stainless steel hardware, etc.
- Handles vials to gallons — plastic, glass or metal, without changeover parts.
- Handles tamper evident caps, child safety caps, overcaps, dispenser caps and specialty caps.
- No bottle - no cap safety release.
- Available with two sets of bottle gripper belts for tall or unstable containers providing complete bottle control.
- Patented clutches provide consistent torque and eliminate product spillage and cross-threading.
- Comes standard with the exclusive Feed Systems® patented stainless steel Rotary Cap Feeder offering quiet and gentle cap orientation with no changeover parts for all standard caps.
- Numerous patented features are incorporated into the design of Kaps-All Cappers to make them the most advanced cappers available. With over 50 years in manufacturing packaging machinery and thousands of capping machines operating worldwide, our cappers have earned the right to be recognized as... "The Proven Standard"®.

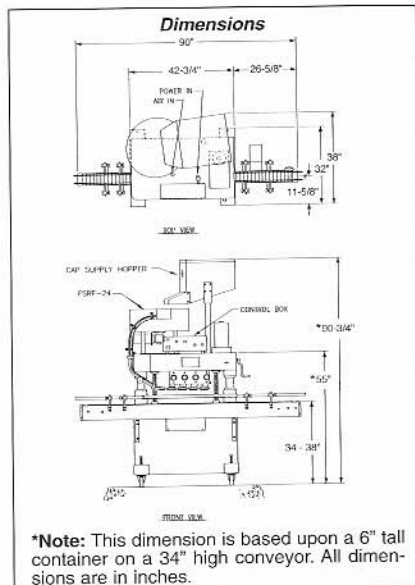

*Due to Kaps-All Packaging Systems, Inc., commitment to maintain its leadership in the capping industry, dimensions and specifications are subject to change without notice.*

## Anatomy of a Kaps-All® Capper

Level sensor to maintain constant level of caps in feeder (Standard).

Patented design Feed Systems® Rotary Cap feeder eliminates change parts for all standard caps, including child resistant and tamper evident (Standard).

Patented Rotary Cap feeders are constructed of stainless steel. (Standard). (Vibratory and Escalator cap feeders also available).

Electronic fiber optics maintain constant supply of caps on demand (Standard).

Patented stainless steel upper and lower cap chutes accommodate all cap sizes and styles from 8mm to 120mm diameters (13mm to 70mm standard).

All adjustments are repeatable with calibrated scale settings for easy changeovers (Standard).

Fully adjustable conveyor guides with patented up-down and in-out adjustments (Standard with conveyor).

Gas purging prior to capping available for sensitive products (Optional).

Exclusive non-marring (FDA approved) oil resistant carrier belts are standard (Pat. Pending).

No changeover parts needed for a wide range of standard cap sizes, container shapes and sizes (Standard).

Patented adjustable capping head accommodates vials to 2-1/2 gallon containers without change parts (Standard).

Designed to overhang existing conveyor or available with optional stainless steel frame conveyor with electronic variable speed drive and Delrin chain with stainless steel pins.

Exclusive patented design, heavy duty multiple disc, adjustable torque clutches give consistent torque without marring caps (Standard).

Stainless steel leveling screws with floor pads (Standard).

Extra heavy duty welded construction, mobile base for full portability (Standard). (Stainless steel optional).

Can handle both screw capping and overcapping (pressure — push-on) on the same machine.

Standard stainless steel Cap Supply Hopper, (shown) or optional patented EASY LOAD® Hopper or optional Feed Systems® Cap Elevator. (See other side).

Cap level viewing window in hopper (Standard). Low profile supply hoppers available.

Patented Electronic Torque Monitor with digital readout and computer interface provides for alarms, low/high rejection and downstream line integration (Optional).

All DC electronically controlled variable speed drives (Standard).

Stainless steel guarding throughout (Standard).

Pneumatic remotely controlled adjustable clutches with dial settings. Simultaneously adjusts clutches while machine is operating (Optional - Patented).

Simple patented knob adjustments to change to different size caps and containers (Standard).

Automatic electric head height adjustment (Optional).

Patent pending stainless steel bottle gripper belt housings (Standard).

Unique design of bottle grippers allow adjustments both up-down and in-out without the need of universal joints (Standard).

Independently adjustable bottle gripper belts for tapered containers and special applications (Patented, Optional).

One or two sets of bottle gripper belts available on all models for complete torque control and no bottle spillage (One set standard).

Two year guarantee — The longest in the industry (Standard).

**Contact us today for more detailed information, pricing and application assistance!**

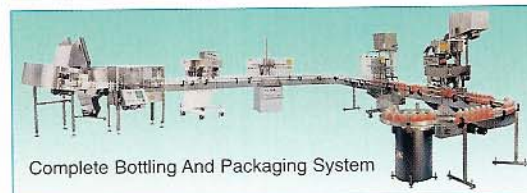

The Proven Standard®... Since 1941.



200 Mill Road, Riverhead, NY 11901-3125 USA

Tel (516) 727-0300 • Fax (516) 369-5939

DEVELOPERS AND MANUFACTURERS OF COMPLETE PACKAGING AND BOTTLING SYSTEMS

- Bottle Cappers • Cap Tighteners • FILLS-ALL® Automatic and Semi-Automatic Liquid Fillers • Bulk Loaders •
- FEED SYSTEMS® Rotary and Escalator Parts Feeders • ORIENTAINER® Bottle Orienters and Unscramblers • Accumulators •
- CLEAN-N-VAC® Bottle Cleaners • CONVEYS-ALL™ Conveyor Systems • Ball Placers • Bottle Carriers • Bottle Sealers •
- EASY KAP® Hand Cappers • Desiccant Inserters • Electronic Torque Metering and Monitoring • Custom Packaging Machinery •

